

PARAVOX™

Voice Dialer Module V2.2
VD710



Reference and Installation Manual

We hope this product performs to your complete satisfaction. Should you have any questions or comments, please visit our website at paradox.com

P **▲** **R** **▲** **D** **O** **X**®
S E C U R I T Y S Y S T E M S

Table of Contents

Introduction	1
System Features	1
Technical Specifications	2
Glossary of Terms	2
Installation	3
Power Connections	3
Telephone Line Connections	3
Zone Input Terminals	5
Programmable Outputs (PGMs)	5
System Reset	6
Basic Operation	6
LED Indicators	6
Green OK LED	6
Red PULSE LED	6
Standby Mode	7
Dialer Mode	7
Installer's Programming Mode	8
Dialing Options	10
Dialing Method	10
Redials	10
Pulse Options	11
Post Pager Message Delay	11
Post Dial Delay	11
Voice Message Options	11
Voice Message Length	12
Voice Message Repeats	12
Kiss Off Options	12
Zone Options	13
Zone Type	13
Idle State	13
Zone Speed	14
Zone 4 Mode	14

PIN Options	15
Change Installer PIN (Default: 777444)	15
Set User PIN Length	15
Set Installer PIN Length	15
Answering Options	16
Rings Before Answering	16
Answering Machine Override	16
Telephone Line Monitoring (TLM)	17
Local Connection Options	17
Local Connection Code	17
Call Progress Options	18
No Dial Tone Action	18

User's Opening Menu18

User's Programming Mode19

Store Telephone Numbers	21
Record Voice or Pager Messages	23
Voice Messages	24
Program Output Labels (messages)	24
Pager Messages	24
Change User PIN (Default: 1234)	25
Installer Instructions for Changing a PIN	26
User Instructions for Changing a PIN	26
Telephone Number Assignment	27
Test Message Sending	28

Programming Data Sheet29

Index31

1.0 Introduction

The ParaVox™ Voice Dialer provides remote voice and pager messaging capabilities for almost any security alarm panel. The ParaVox can advise users of almost any security situation such as burglary, fire, or flood by calling the user and playing a pre-recorded message or by paging and leaving a numerical message.

Fully programmable over the telephone (locally or from an external line), the ParaVox guides the end user through all system functions with a full set of voice prompts (no external keypad required). All the user needs to remember is their P.I.N. (Personal Identification Number).

The ParaVox Voice Dialer has four input zones, programmable to accept a variety of input configurations and devices. These zone inputs can be linked to four different 32-digit telephone or pager numbers delivering up to eight different messages (4 voice and 4 pager). Programmable dial-out priority allows the dialer to contact the most important number first. Based on the installation requirements, the ParaVox can use two 30 second messages or four 15 second messages.

The ParaVox's two programmable outputs can be used for remote activation of almost any device by telephone, such as turning on air conditioning or heat, extinguishing lights, activating a sprinkler system, or opening a garage door.

1.1 System Features

- Voice and Pager Dial-out Capable
- Remote programming from any DTMF capable telephone
- The dialer can be configured to provide four 15 second messages or two 30 second messages
- Automatic Gain Control (AGC) provides excellent recorded speech quality
- Both DTMF and Pulse Dialing
- Each zone can dial-out a maximum of four 32-digit telephone numbers individually allocated for either voice or pager
- Dial-out priority can be set for each zone, enabling the most important number to be dialed first
- All system information, messages, telephone, pager and PIN numbers are stored in secure NV (non-volatile) RAM

- Kiss off Options: Users can terminate received alarm activation message of current call (press **[#]** twice) or of all pending calls (press **[*]** twice)
- No Dial Tone Option: Wait 8 seconds for dial tone and continue to dial or wait 16 seconds for dial tone and hang up
- Post Pager Message Delay: After dialing the pager number, ParaVox will wait the programmed delay period before sending the message
- Local Reset Feature: Zone 4 can be used as a local reset switch, which when activated will cancel all calls from a currently triggered zone
- Communicate with ParaVox through a local phone (a phone on the same phone line as ParaVox) by pressing the **[#]** or **[*]** key twice or by generating a 4-digit code.

1.2 Technical Specifications

Input Voltage:	12 to 16Vdc (12.5Vdc typical)
Current Consumption:	Typical: 100mA Maximum: 200mA (with 2 PGMs enabled)
Power Consumption:	1 Watt
Zone Inputs:	4 (N.C., N.O., 1K/2K EOL, 12Vdc input)
PGM Outputs:	2
PGM Output Current:	50mA
Operating Temperature:	0°C to 50°C (32°F to 122°F)
Dialing Modes:	Pulse, DTMF
Message Storage Length:	4 x 15s or 2 x 30s
Voice Quality:	44.1KHz sample rate with AGC
Dimensions (w/case):	16.5cm x 15.2cm x 2.8cm (6.5in x 6in x 1.1in)

1.3 Glossary of Terms

PSTN	Public Switched Telephone Network
PABX	Private Access Branch Exchange
PIN	Personal Identification Number
DTMF	Dual Tone Multiple Frequency
EOL	End of Line
PPS	Pulses Per Second
Kiss off	User acknowledges receipt of voice messages by pressing the [#] or [*] key twice within 2 seconds. Kiss off can also be performed locally if Zone 4 is programmed as a Local Reset switch.

2.0 Installation

2.1 Location and Mounting

Mount the ParaVox Voice Dialer on a wall, leaving at least 5cm (2in) around the panel box to permit adequate ventilation/heat dissipation. Verify that the selected site is even and free of bumps which may damage the product casing. Select a dry installation site that isn't susceptible to drastic changes in temperature and is close to a 12Vdc-power source, a ground, and a telephone line connection. Using a drill or screwdriver, punch out the four mounting holes on the back of the plastic case. Align the six holes of the printed circuit board (PCB) with the six pins on the back plastic mounting case and snap into place. After completing required wiring, run the wires through the entry hole on the back of the plastic case and screw the back of the plastic case onto the selected installation site and affix the plastic cover.

2.2 Power Connections

The auxiliary terminals (12Vdc) of any Paradox series control panel can be used to power the ParaVox by connecting the **AUX+** and **AUX-** of the control panel to the **+12VDC** and **GND** terminals of the voice dialer. If desired, a Paradox 12Vdc PS-817 Power Supply and a 12Vdc backup battery can be used to power the ParaVox. Refer to Figure 1 on page 4.

2.3 Telephone Line Connections

The ParaVox Voice Dialer has been designed to be connected to a PSTN or a PABX telephone system. It places outgoing calls in response to zone input changes and seizes incoming calls when entering programming mode. The telephone line terminals are connected as shown in Figure 1 on page 4.

In addition to dialing the number of the telephone line that the ParaVox is connected to, you may now use a local phone (a phone on the telephone line) to program the ParaVox. Simply pick up the handset and dial either **#[#]** or **#[*]**, depending on how the kiss off is programmed. Please see *Kiss Off Options* on page 12 for more information.

Figure 1: ParaVox Installation Diagram

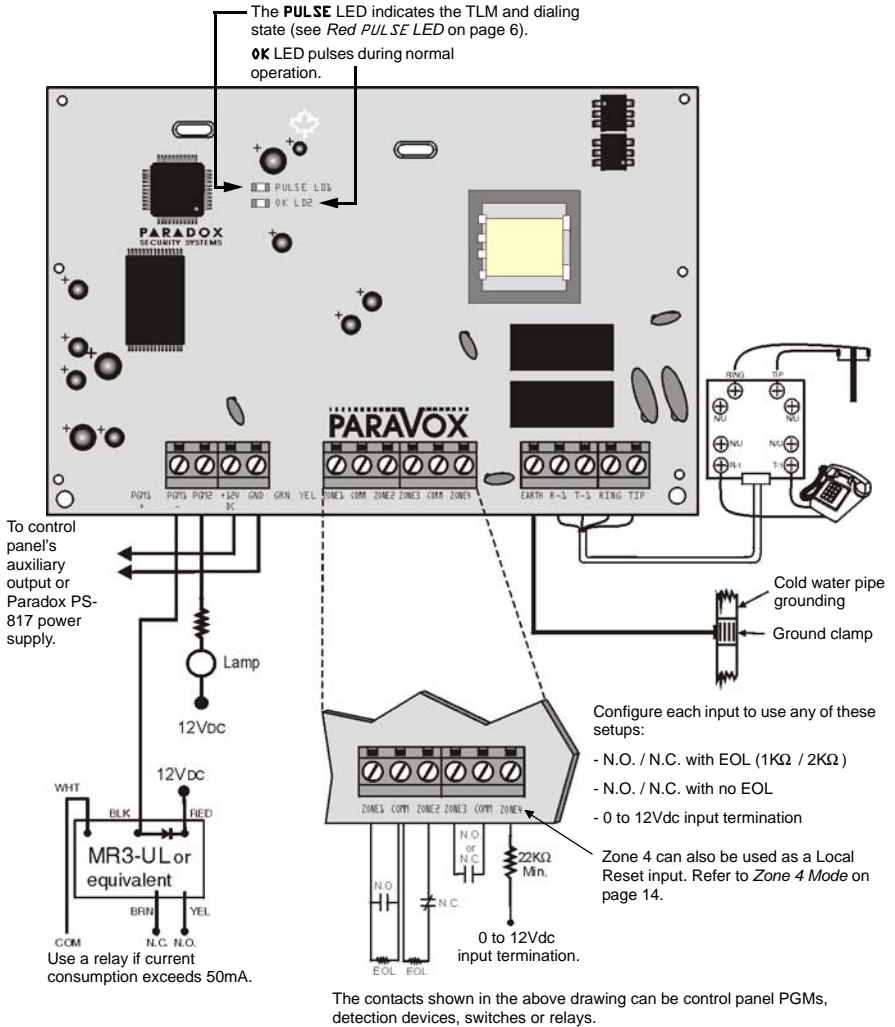

2.4 Zone Input Terminals

Up to four zone inputs can be used to initiate a dial-out to pre-programmed telephone or pager numbers. When the ParaVox recognizes a change at the zone input, it will proceed with the programmed dial-out. Each zone input can be configured to use normally open or normally closed triggering with or without an EOL resistor (1k Ω /2k Ω). Each zone input must be in its triggered or active state for longer than the programmed Zone Speed (see *Zone Speed* on page 14) before the ParaVox will dial-out. Please refer to *Zone Options* on page 13 for more information on how to program these termination methods. Refer to Figure 1 on page 4 for more information.

Example:

Connect the output of a control panel's PGM to zone input 1 as shown in Figure 1 on page 4. Program the PGM to activate when there is an alarm. When an alarm occurs in the control panel, the PGM output will activate (close). The ParaVox will recognize this change and proceed to dial-out as defined by the Telephone Number Assignment for zone input 1 (see *Telephone Number Assignment* on page 27).

A 12Vdc input termination method is also available. Using this method, the ParaVox will verify the voltage levels of a device connected to its input and responds accordingly depending on the programmed Idle State (see *Idle State* on page 13). To ensure reliable triggering when using the 0-12Vdc-termination method, connect a 22k Ω resistor in series.

2.5 Programmable Outputs (PGMs)

Two outputs (PGM1 and PGM2) are available on the ParaVox for remote switching of other devices. A user can remotely activate (close) or deactivate (open) the output by calling the ParaVox and pressing the appropriate key (see *User's Opening Menu* on page 18). For example, a PGM can be used to turn on air conditioning or heat, extinguish lights, activate a sprinkler system, or open a garage door. When activated, a PGM provides a maximum 50mA current sink to 0Vdc. If the load on the PGM will exceed 50mA, we recommend using a relay as shown in Figure 1 on page 4.

2.6 System Reset

Performing a system reset will set all options and settings to factory default. To execute a system reset perform the following:

1. Remove the power connections (**+12VDC** and **GND**) from the ParaVox.
2. Remove all connected wires and devices from the **PGM1-** and **ZONE1** terminals.
3. Short the **PGM1-** and **ZONE1** terminals by placing a wire between **PGM1** and **ZONE1** of the ParaVox (see Figure 2).
4. Reconnect the power connections to the ParaVox.
5. Wait 10 seconds and remove the wire.

Figure 2

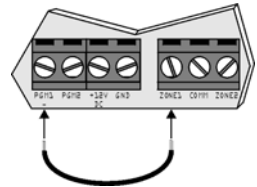

3.0 Basic Operation

3.1 LED Indicators

3.1.1 Green OK LED

- When the ParaVox is powered and is operating normally, the **OK** LED will flash.

3.1.2 Red PULSE LED

- With the ParaVox in its idle state and with TLM disabled (see *Telephone Line Monitoring (TLM)* on page 17), the **PULSE** LED is off.
- With the ParaVox in its idle state and with TLM enabled, the LED will flash briefly every second indicating that it is verifying the telephone line. If the telephone line is not present, the LED will flash (1 second ON and 1 second OFF) to indicate TLM failure.
- When the ParaVox is pulse dialing, the LED will pulse in sync with the dialing sequence. When the ParaVox is tone dialing, the LED will remain on for the duration of the dialing sequence.

3.2 Standby Mode

In this mode, the voice dialer is idle (OK LED flashes), waiting for one of two events to occur:

1. When one of the four zone inputs on the ParaVox has triggered, the voice dialer immediately enters Dialer Mode (see *Dialer Mode* on page 7).
2. When receiving an incoming call, the ParaVox waits a pre-determined number of rings (see *Answering Options* on page 16), seizes the line and enters Programming Mode. If the ParaVox is sharing a line with an answering machine, see *Answering Machine Override* on page 16.

3.3 Dialer Mode

When a zone input has triggered, the ParaVox:

1. Seizes the telephone line and disconnects all other telephones.
2. Waits for a dial tone (see *No Dial Tone Action* on page 18).
3. Dials the first telephone/pager number assigned to the triggered zone input (see *Telephone Number Assignment* on page 27). If it is a Voice Message Number go to step 4. If it is a Pager Number go to step 7.

Voice Message Number:

4. After dialing the number and after the Post Dial Delay has elapsed (see *Store Telephone Numbers* on page 21), the ParaVox will begin transmitting the recorded message linked to the triggered zone (see *Record Voice or Pager Messages* on page 23). It will transmit the message the number of times defined by the Voice Message Repeats (see *Voice Message Repeats* on page 12).
5. The user must acknowledge receipt (kiss off) of the message (see *Kiss Off Options* on page 12). If the ParaVox does not receive a kiss off, it will hang up, queue the number for redial and dial the next number in the dial-out list.
6. If, after dialing the number, there is a busy signal, the ParaVox will hang up, queue the number for redial, wait for 4 seconds and dial the next number in the dial-out list.

Pager Number:

7. After dialing the number and after the Post Pager Message Delay has elapsed, the ParaVox will begin transmitting the recorded numerical message linked to the triggered zone (see *Record Voice or Pager*

- Messages* on page 23).
8. After transmitting the message it will hang up and dial the next number in the dial-out list. Since the ParaVox assumes that the pager service has received and relayed the message, user acknowledgment (kiss off) is not required and the ParaVox no longer attempts to dial this number again regardless of the number of Redials programmed (see *Redials* on page 10).
 9. If, after dialing the number, there is a busy signal, the voice dialer will hang up, queue the number for redial, wait for 4 seconds and dial the next number in the dial-out list.

Dial-Out List:

For example, if zone input 1 has been assigned to dial telephone number locations 1 and 2 and the Redials are set to 2, then the Voice Dialer will dial out as follows:

- 1st attempt: Call TEL1 and then call TEL2
- 1st redial: Call TEL1 and then call TEL2
- 2nd redial: Call TEL1 and then call TEL2



Please note that pager numbers are dialed only once (regardless of the Redials setting) unless the number is busy. Also note that telephone numbers are not redialed once kiss off is received.

4.0 Installer's Programming Mode

The Installer's Programming Mode allows you to set certain parameters that are not available in the User's Programming Mode. In the Installer's Programming Mode there aren't any voice prompts to guide you. However, when a programmable setting has been programmed, you will hear a confirmation beep (3 beeps) and the ParaVox will save and exit. When choosing a selection that isn't available, the telephone will emit a rejection beep (1 long beep).

Programming Example: Change number of Redials to 2.

1. Dial the ParaVox telephone number (“*Hello, please enter your PIN*”). If your telephone is connected directly to the unit, press the [#] or [*] key twice. Please see *Kiss Off Options* on page 12 for more information.
2. Enter a valid Installer PIN.
3. Press [1] to program Dialing Options.
4. Press [2] to program Redials.
5. Press [2] to set Redials to 2.
6. Automatically saves and exits.

Pressing the [*] key at any time reverts to the previous section without saving. In most situations, users and installers can type over voice prompts rather than waiting for the prompt to end. The ParaVox will hang up if no actions are made after approximately 60 seconds.

To enter Installer's Programming Mode:

1. Dial the telephone number to which the ParaVox Voice Dialer is connected. When the Voice Dialer answers (see *Rings Before Answering* on page 16), you will hear “*Hello, please enter your PIN.*”
2. On your telephone keypad, key in the Installer PIN (default: 777444)
A confirmation beep (beep, beep, beep) indicates that the PIN was accepted.
3. Select an action from the Installer's Main Menu:

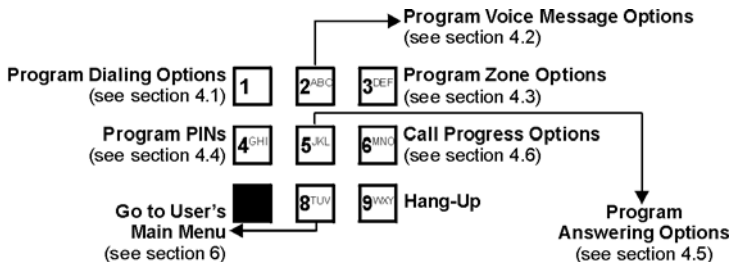

4.1 Dialing Options

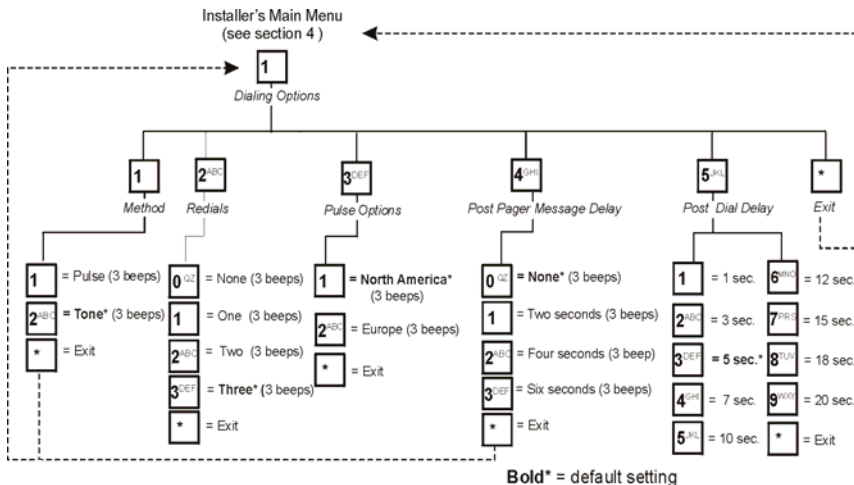

4.1.1 Dialing Method

The ParaVox can use Pulse or Tone (DTMF) dialing. The ParaVox automatically switches to tone dialing when transmitting pager messages.



Please note that pulse dialing is not recommended and if used, proper operation is not guaranteed.

4.1.2 Redials

This parameter defines how many times (excluding the first attempt) the ParaVox will redial the same telephone number if a busy signal is detected or if it hasn't received a kiss off from the user. Since the ParaVox assumes the pager service has received and relayed the message, the ParaVox does not redial pager numbers unless the number was busy. Please note that the ParaVox does not immediately redial the same number. It will dial any other numbers in the Dial-Out List (see *Dialer Mode* on page 7) before returning to the same number (i.e. #1, #2, #1, #2 **NOT** #1, #1, #2, #2).

4.1.3 Pulse Options

When using Pulse Dialing, the ParaVox can use North American (1:1.5 ratio, 10PPS) or European (1:2 ratio, 10PPS) dialing characteristics.

4.1.4 Post Pager Message Delay

After dialing the pager number, ParaVox will wait the programmed delay period before sending the message. After sending the message, ParaVox will hang up. The Post Pager Message Delay can be set to zero, two, four, or six seconds.

4.1.5 Post Dial Delay

After dialing the phone number, ParaVox will wait the programmed delay period before sending the voice message. After sending the message, ParaVox will hang up. The Post Dial Delay can be set to 1, 3, 5, 7, 10, 12, 15, 18, or 20 seconds.

4.2 Voice Message Options

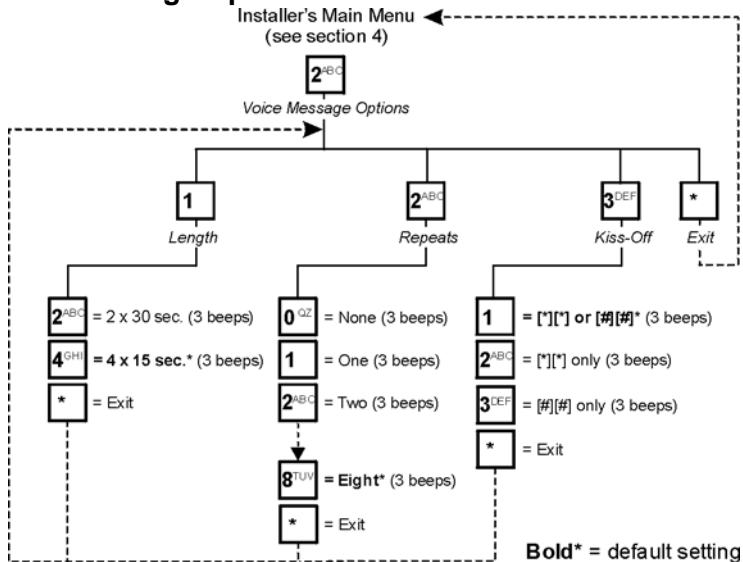

4.2.1 Voice Message Length

The ParaVox can be configured to provide either two 30 second messages or four 15 second messages. Refer to *Record Voice or Pager Messages* on page 23 for information on how to record these messages.



Please note that every time the Voice Message Length is programmed, the ParaVox will erase any existing messages and will use the default messages until a new message is recorded.

4.2.2 Voice Message Repeats

This sets the number of times that the ParaVox will repeat the recorded voice message once the called party has answered or the Post Dial Delay period (see *Store Telephone Numbers* on page 21) has expired.

4.2.3 Kiss Off Options

The kiss off options can be set as shown in the figure in section 4.2 on page 11.

To acknowledge receipt (kiss off) of a message and to cancel any further dialing attempts to this number, the user must press the **[#]** key twice within 2 seconds. After kiss off, the ParaVox will dial the next number in the dial-out list and it will no longer attempt to dial this number again regardless of the number of Redials programmed (see *Redials* on page 10).

To acknowledge receipt (kiss off) of a message and to cancel any further dialing attempts to **all** numbers assigned to the triggered zone, the user must press the **[*]** key twice within 2 seconds. After kiss off, the ParaVox will say “Goodbye” and hang up. If the ParaVox does not receive a kiss off, it will hang up, queue the number for redial and dial the next number in the dial-out list.

4.3 Zone Options

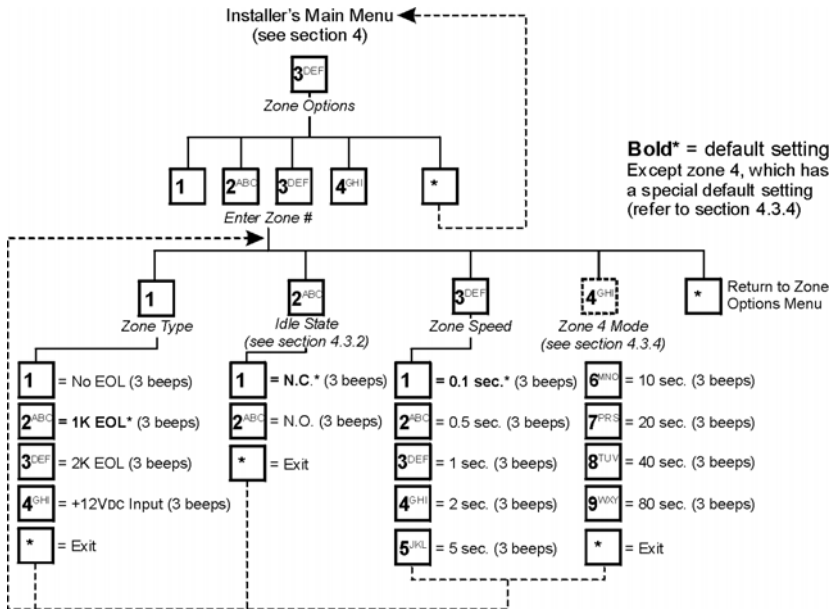

4.3.1 Zone Type

The following zone input terminations can be selected for each zone input: 1K, 2K, or no EOL or 0-12Vdc input termination (see *Zone Input Terminals* on page 5).

4.3.2 Idle State

This parameter defines the idle state (N.O. or N.C.) of the device connected to each zone input. If using the 0-12Vdc input termination method (see *Zone Input Terminals* on page 5), the Idle State functions as indicated in the table below.

- | |
|---|
| <p>[1] N.C.: 0V to 4.33V = Alarm (initiates dial-out)
4.33 to 12V = O.K (normal)</p> <p>[2] N.O.: 0V to 4.33V = O.K (normal)
4.33 to 12V = Alarm (initiates dial-out)</p> |
|---|

4.3.3 Zone Speed

The Zone Speed parameter defines how long a zone input must remain in its opposite state (triggered) before the ParaVox responds to the triggering of the zone input. This feature prevents any momentary glitches in the system from causing unnecessary dial-outs. Each zone input can be set with a Zone Speed of 0.1 seconds to 80 seconds.

4.3.4 Zone 4 Mode

If you select option **[1]**, the ParaVox will process zone 4 like any other zone in the voice dialer. Zone 4 will be considered normal.

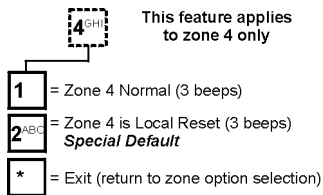

If you select option **[2]**, zone 4 can be used as a local reset (kiss off). Program the appropriate Zone Options and when zone 4 has met the trigger requirements (Zone Options), the ParaVox will cancel all pending calls assigned to the currently triggered zone (zones 1 to 3).

Special Defaults for Zone 4:

- Local Reset (kiss off) enabled
- No EOL resistor
- Normally Open
- Zone Speed is one second

4.4 PIN Options

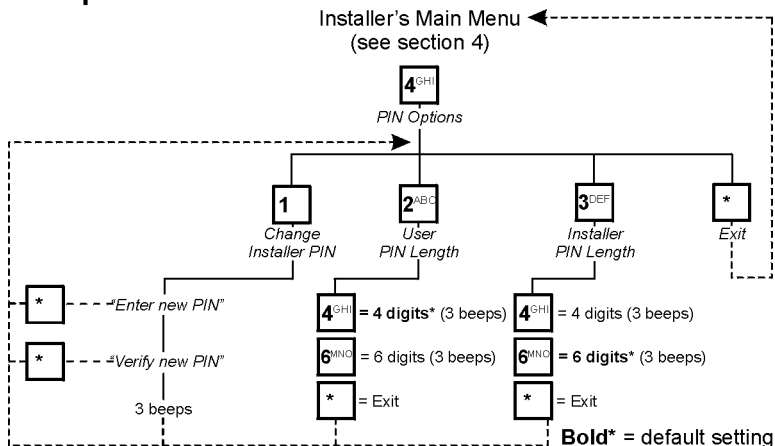

4.4.1 Change Installer PIN (Default: 777444)

To change the installer PIN, enter the new 4-digit or 6-digit number twice. Voice prompts will be played in this section indicating when to enter the PINs. This will be verified by 3 short beeps. Press the [*] at any time to cancel the change.

4.4.2 Set User PIN Length

The User PIN length can be set to four or six digits (default: 4 digits).

4.4.3 Set Installer PIN Length

The Installer PIN length can be set to four or six digits (default: 6 digits).



We recommend using the default User & Installer PIN Lengths. Otherwise, a user can accidentally enter the Installer's Programming Mode or accidentally change the Installer's PIN. When you change the PIN Length from 4 digits to 6 digits, the ParaVox will automatically add the last 2 digits by using the first 2 digits. For example, if the PIN is 1234 it will become 123412. When you change the PIN Length from 6 digits to 4 digits, the ParaVox will automatically remove the last 2 digits.

4.5 Answering Options

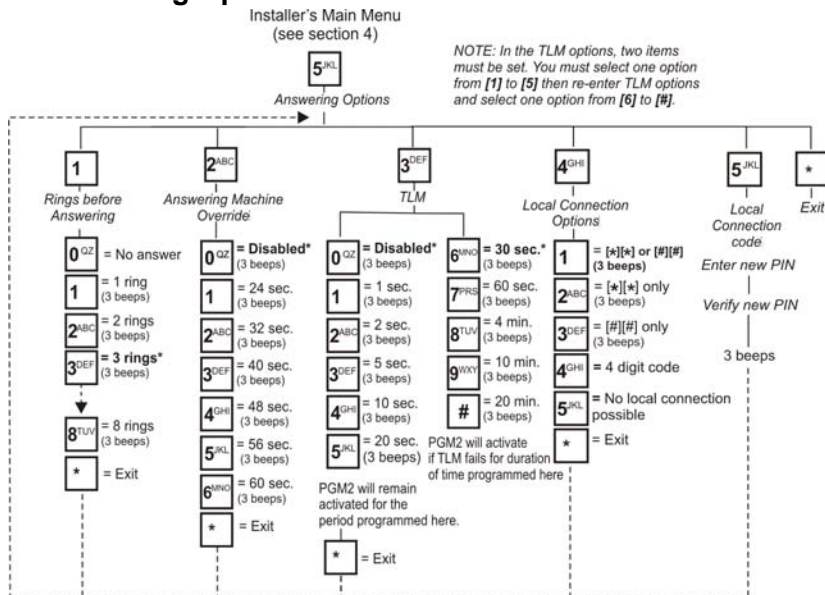

4.5.1 Rings Before Answering

This parameter determines how many rings the ParaVox will wait before answering the telephone call. This parameter can be set from 1 to 8 rings. If an answering machine is on the same line as the ParaVox, please refer to the Answering Machine Override option (see section 4.5.2). **Set this parameter to a minimum of two rings in order for this feature to function correctly.**

4.5.2 Answering Machine Override

If there is an answering machine on the same line as the ParaVox, you must set the Rings Before Answering (see section 4.5.1) to more than the number of rings required for the answering machine to answer. The user then calls the ParaVox and hangs up before the programmed number of rings. If the user redials (waiting at least 10s) within the period defined by the Answering Machine Override option (24-60s), the ParaVox will immediately pick up the line.

4.5.3 Telephone Line Monitoring (TLM)

Telephone Line Monitoring checks the telephone line every second to see if it is still connected. In the TLM Options Menu, two different items must be programmed.

1. If the line is disconnected for longer than the period defined by options **[6]** to **[#]** (see Figure in *Rings Before Answering* on page 16), the ParaVox will activate PGM2.
2. When PGM2 is activated, PGM2 will remain activated for the period defined by options **[1]** to **[5]** (see *Answering Options* on page 16). PGM2 will continue to re-trigger for as long as the line is disconnected. To completely disable TLM, set the TLM option to **[0]**.

4.5.4 Local Connection Options

Numerous options are offered to access the ParaVox voice dialer from a local phone connection.

1. Choose options **[1]** to **[3]** from the Local Connection Options to use different **[*][*]** and **[#][#]** combinations.
2. Choose option **[4]** from the Local Connection Options menu, to access the system using a 4-digit code. To change the code, go to the Local Connection Code menu.
3. Choose option **[5]** from the Local Connection Option menu, to disable access to the voice dialer through the local line connection. An outside line must be used.

4.5.5 Local Connection Code

The local connection code can be changed. It is strongly suggested that the codes include the symbols **[*]** and/or **[#]** to prevent the sequence from being accidentally activated. The default local code is **[*][#][*][#]**.

4.6 Call Progress Options

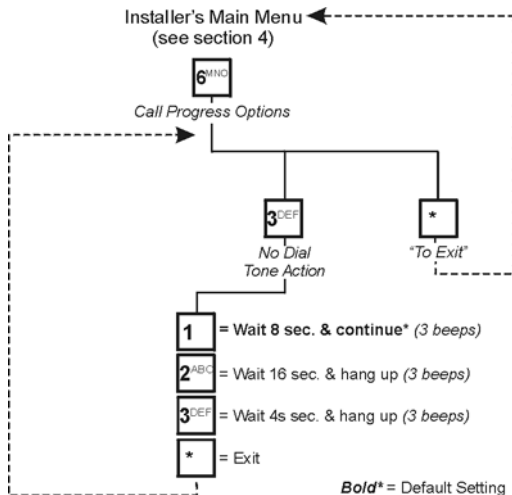

4.6.1 No Dial Tone Action

With option **[1]** selected, the ParaVox will continue to dial if no dial tone is present after 8 seconds. With option **[2]** selected, the ParaVox will hang-up if no dial tone is present after 16 seconds.

5.0 User's Opening Menu

The User's Opening Menu allows a user to activate or deactivate the programmable outputs and enter the User's Programming Mode (see *User's Programming Mode* on page 19). Please note that while in any of the user menus, detailed voice prompts will guide the user through the available selections. Also note that pressing the [*] key at any time will revert to the preceding section without saving. In most situations users and installers can type over voice prompts rather than waiting for the prompt to end. The ParaVox will repeat the voice prompts four times. If no actions are made in this time, the ParaVox will hang up. To enter the User's Opening Menu:



Call the ParaVox Voice Dialer.

*If there is an answering machine sharing the same line, refer to *Answering Machine Override* on page 16. If you are calling from a local phone (on the same phone line as the ParaVox), press **#[#]** or ***[*]** or a 4-digit code (see the 'Answering Options' graphic on page 17).



"Hello, please enter your PIN."



Key in the User PIN (default: 1234).



"Output one is <on/off>. Output two is <on/off>."

This message can be programmed see section 6.3



Select the desired action as shown below.

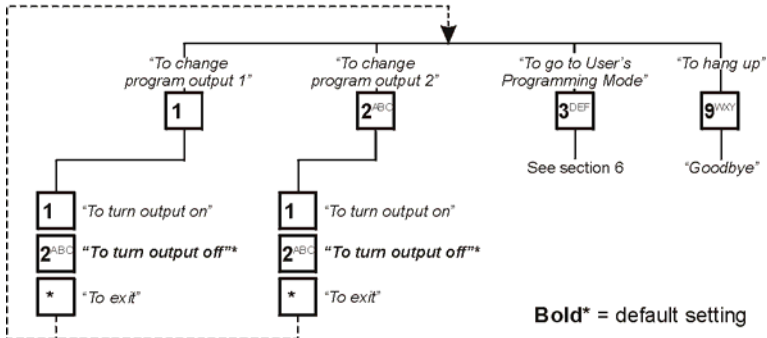

6.0 User's Programming Mode

By entering the User's Programming Mode, you can set most of the ParaVox's parameters. Please note that while you are in any of the user menus, detailed voice prompts will guide you through the available selections. Also, note that pressing the **[*]** key at any time will revert to the previous section without saving. In most situations you can type over voice prompts rather than waiting for the prompt to end. The ParaVox will repeat the voice prompts four times. If no actions are made during this time, the ParaVox will hang up.

User	Installer
To enter the User's Programming Mode, press the [3] key from the User's Opening Menu (page 18).	To enter the User's Programming Mode, press the [8] key from the Installer's Main Menu (page 8).

User's Main Menu

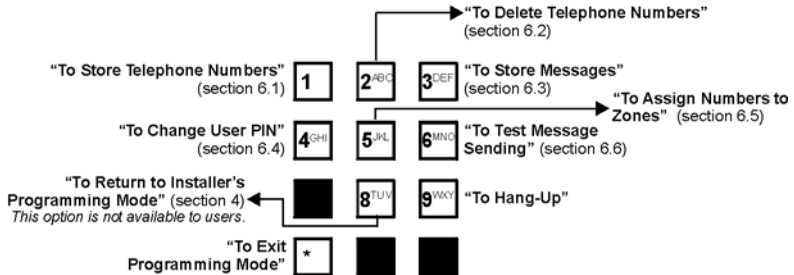

6.1 Store Telephone Numbers

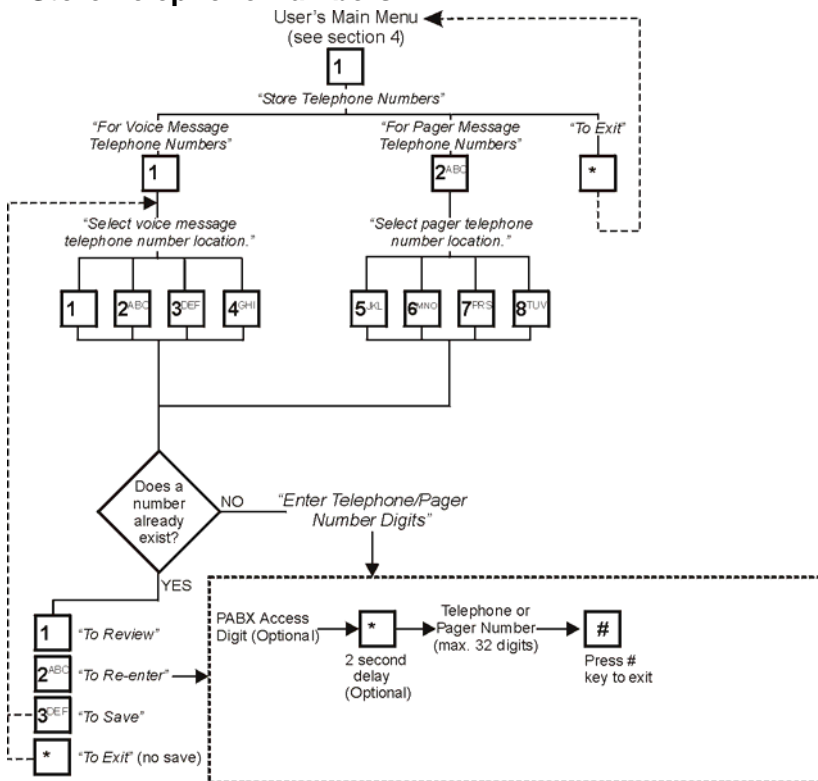

The ParaVox unit can store up to four telephone numbers in locations [1] to [4] and up to four pager numbers in locations [5] to [8]. When a telephone number is assigned to a zone input (see *Telephone Number Assignment* on page 27), the ParaVox will dial the programmed number whenever the zone input is triggered.



When programming numbers, do not wait more than 4 seconds between key presses. After entering a number, make sure to press the [#] key.

Delete Telephone and Pager Numbers

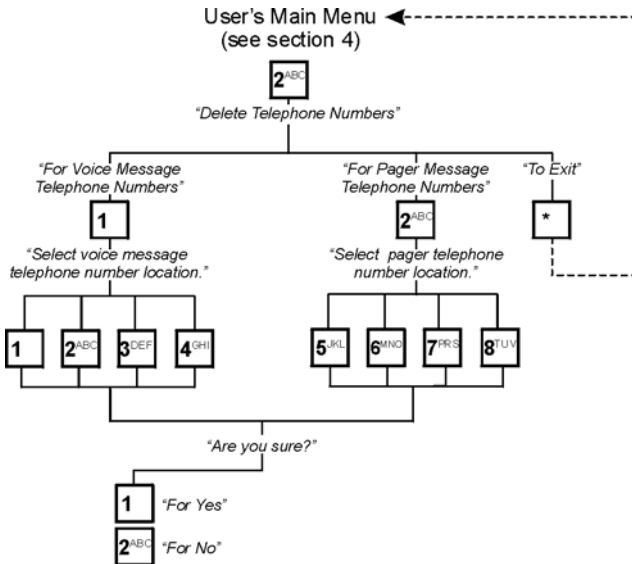

Previously stored voice message telephone numbers and pager telephone numbers can be deleted by entering option [1] or [2] from the Delete Telephone Numbers Menu. Select the desired voice message telephone or pager number location. Deletion is confirmed by entering [1] for yes or [2] for no.



When you delete a telephone number, the ParaVox will automatically remove the number from all zone assignments.

6.2 Record Voice or Pager Messages

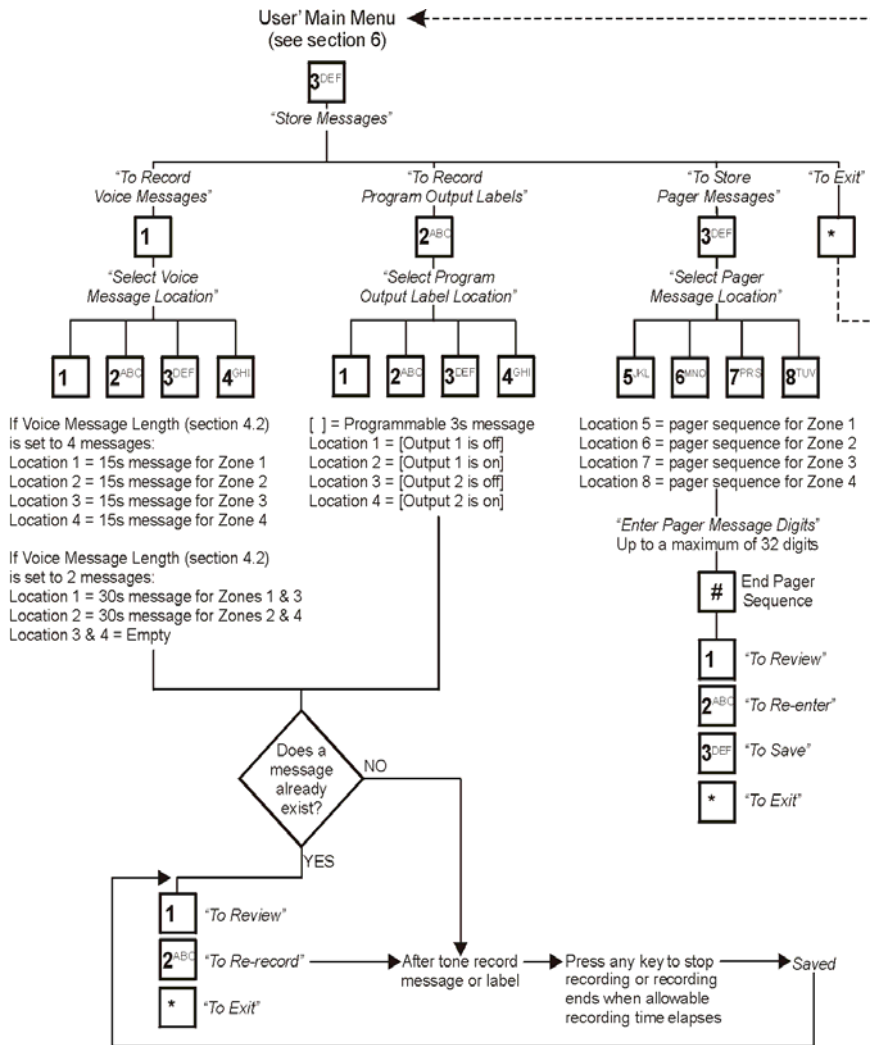

6.2.1 Voice Messages

If key [1] is selected from the Store Messages Menu, you will be able to record voice messages. Depending on the selected Voice Message Length (see *Voice Message Length* on page 12) you will be able to record two 30 second messages or four 15 second messages. Each recorded message is linked to a specific zone input as shown in the *Record Voice or Pager Messages* on page 23. When a triggered zone has been programmed to dial-out a voice message telephone number (see *Telephone Number Assignment* on page 27) and when the number is reached, the voice dialer will play the recorded message linked to the triggered zone.

Default Messages:

"Trigger of zone x detected. Key pound twice or star twice to accept."

Sample Voice Messages:

"Liquid level above normal"

"Smoke detected in the archive room"

We recommend adding the following to your voice messages:

"...press the [#] or [] key twice to acknowledge message"*

6.2.2 Program Output Labels (messages)

Selecting the [2] key from the Store Messages Menu allows the user to record voice prompts linked to the programmable outputs (3 seconds maximum) as shown in the diagram on page 23. These messages are played when entering the User's Opening Menu and when changing the state of the PGMs (see *User's Opening Menu* on page 18).

Default Labels (messages):

"Output 1 is <on/off>"

"Output 2 is <on/off>"

Sample Program Output Labels:

"Garage door is open"

"Air conditioning is off"

6.2.3 Pager Messages

If key [3] is selected from the Store Messages Menu, you will be able to record numerical pager messages. Up to four 32-digit pager messages can be programmed, each of which is linked to a specific zone input as shown in *Record Voice or Pager Messages* on page 23. When a

triggered zone has been programmed to dial-out a pager number (see *Telephone Number Assignment* on page 27) and when the number is reached, the voice dialer will transmit the recorded numerical message linked to the triggered zone.

Example:

In the following example notice how the messages are linked to the triggered zone and not the telephone numbers.

Zone 4 is programmed to dial telephone numbers 1 and 2. When zone 4 has triggered, the ParaVox will dial the telephone number stored in telephone number location 1. After the Post Dial Delay, the ParaVox will play the message recorded in Voice Message Location 4. The ParaVox will proceed by dialing the number recorded in telephone number location 2. After the Post Dial Delay, the ParaVox will play the message recorded in Voice Message Location 4.

6.3 Change User PIN (Default: 1234)

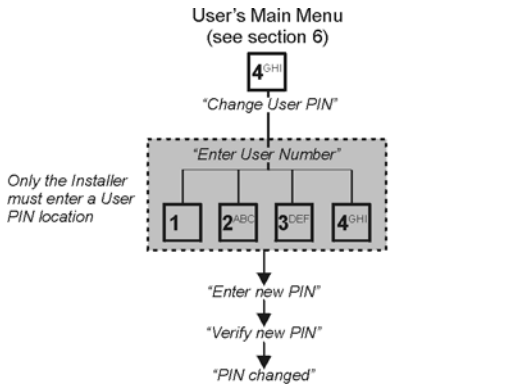

Press the [*] at any time to revert to the *User's Main Menu* without saving.

The ParaVox system supports up to four user PINs, which can be 4 or 6 digits in length as defined in *Set User PIN Length* on page 15.

6.3.1 Installer Instructions for Changing a PIN

After entering the User's Programming Mode, press the **[4]** key to enter the Change User PIN Menu. Select which user PIN from **[1]** to **[4]** that you wish to change and enter the new PIN twice. The **[*]** key can be pressed at any time to exit without saving.

6.3.2 User Instructions for Changing a PIN

After entering the User's Programming Mode, press the **[4]** key to enter the Change User PIN Menu. Enter the new PIN twice (please note that the user does not have to select a user PIN location). After entering the PIN twice, the ParaVox automatically saves the PIN in a user PIN location. Users can only change their own PINs (the PIN used to enter the User's Main Menu). The **[*]** key can be pressed at any time to exit without saving.

When programming a user PIN for the first time, the user must enter the User's Main Menu using the default user PIN (**1234**). Then change the PIN to the desired number. To program subsequent user PINs, the user must exit and re-enter the User's Main Menu using the default PIN.



Please note that the default user PIN (1234) is only erased after programming all 4 user PINs. Therefore, if only one user is going to use the system, we recommend programming the same user PIN in all four locations in order to erase the default PIN.

6.4 Telephone Number Assignment

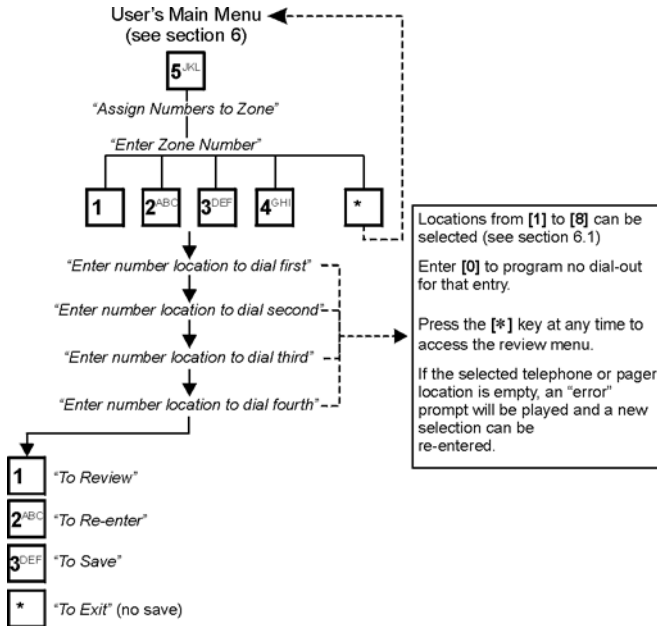

The ParaVox can assign up to four telephone or pager numbers to each of the four zone inputs. This means each zone has a prioritized sequence of dial-outs customized to suit the input. Since voice and pager messages are linked to specific zones, telephone numbers assigned to a zone will play the same voice messages and pager numbers will send the same numerical message.

The user selects the desired zone input and enters up to four telephone and/or pager number locations (one through eight) in the order of dial-out preference. If a location that corresponds to an empty voice or pager number is selected, an error message is played and the user can enter another location. To disable a zone input, enter zero in all four number locations for that zone, or wire the zone input to never trigger. Press the [*] star key after the last entry to enter less than four entries and access the Review Menu.

6.5 Test Message Sending

The User may test the dialer functionality by entering the Test Message Sending Menu and entering a digit between one and eight corresponding to the desired telephone number location (see *Store Telephone Numbers* on page 21). If an empty location is selected (no number is stored there), the error prompt will be played. Another selection can then be entered.

After selecting the desired telephone number location, the ParaVox will dial the selected telephone number and after the Post Dial Delay it will play the message recorded in Message Location 1.



Telephone numbers 1 to 4 will always play the voice message stored in Voice Message Location 1. Pager numbers 5 to 8 will always play the pager message stored in Pager Message Location 5.

Example:

To test the message transmission of telephone number 4, press the [6] key from the User's Main Menu, then press the [4] key to select Telephone Number Location 4. The ParaVox will dial the number stored in Telephone Number Location 4. When the Post Dial Delay has elapsed, the ParaVox will transmit the message programmed in Voice Message Location 1.

7.0 Programming Data Sheet

The following pages have been provided to record the ParaVox's settings.

Personal Identification Numbers (PINs)

User PIN Length (section 4.4.2): _____

Installer PIN Length (section 4.4.3): _____

User PIN 1 (section 6.3): _____ Default: 1234

User PIN 2 (section 6.3): _____ Default: 1234

User PIN 3 (section 6.3): _____ Default: 1234

User PIN 4 (section 6.3): _____ Default: 1234

Installer PIN (section 4.4.1): _____ Default: 777444

Telephone and Dialing Parameters

Dialing Method (section 4.1.1): _____ (Pulse/Tone)

Redials (section 4.1.2): _____ (0 to 3)

Pulse Options (section 4.1.3) _____ (N. America/Europe)

Post Pager Delay (section 4.1.4): _____ (0, 2, 4, or 6 sec.)

Post Dial Delay (section 4.1.5): _____ (1, 3, 5, 7, 10, 12, 15, 18, or 20 sec.)

Rings for Answering (section 4.5.1): _____ (1 to 8)

Ans. Override (section 4.5.2): _____ (24 to 60 sec.)

TLM (section 4.5.3): _____ [0] to [5] _____ [6] to [#]

Call Progress Options

No Dial Tone Action (section 4.6.1): _____

Voice Message & Pager Telephone Numbers (section 6.1)

Location 1 #: _____

Location 2 #: _____

Location 3 #: _____

Location 4 #: _____

Location 5 #: _____

Location 6 #: _____

Location 7 #: _____

Location 8 #: _____

Recorded Voice Messages (section 6.2.1)

Message Length (section 4.2.1): _____ (2 x 30s or 4 x 15s)

Message Repeats (section 4.2.2): _____ (1 to 8)

Kiss off Options (section 4.2.3) _____ (**, ##, or both)

Location 1 / Zone 1: _____

Location 2 / Zone 2: _____

Location 3 / Zone _____

Location 4 / Zone 4: _____

Recorded Pager Messages (section 6.2.3)

Location 5 / Zone 1: _____

Location 6 / Zone 2: _____

Location 7 / Zone 3: _____

Location 8 / Zone 4: _____

Recorded Output Labels (section 6.2.2)

Location 1 / Output 1 off: _____

Location 2 / Output 1 on: _____

Location 3 / Output 2 off: _____

Location 4 / Output 2 on: _____

Assign Numbers to Zones (section 6.4)

	1st Location	2nd Location	3rd Location	4th Location
Zone 1:	_____	_____	_____	_____
Zone 2:	_____	_____	_____	_____
Zone 3:	_____	_____	_____	_____
Zone 4:	_____	_____	_____	_____

Zone Options (section 4.3)

	Zone Type	Idle State	Zone Speed	Notes
Zone 1:	_____	_____	_____	_____
Zone 2:	_____	_____	_____	_____
Zone 3:	_____	_____	_____	_____
Zone 4:	_____	_____	_____	_____

Zone 4: Local Reset Option (section 4.3.4): _____ (enabled/disabled)

8.0 Index

A

- Answering Machine Override 16
- Answering Options 16
 - Answering Machine Override 16*
 - Rings Before Answering 16*
 - Telephone Line Monitoring 17*
- Assign Telephone Numbers 27
- Assigning Telephone Numbers 27

B

- Basic Operation 6

C

- Cadence Options See Call Progress Options
- Call Progress Options 18
 - No Dial Tone Action 18*
- Change Installer PIN 15
- Change User PIN 25
- Changing User PIN if Installer 26
- Changing User PIN if User 26
- connecting power 3
- connecting telephone lines 3
- Connecting the Telephone Line 3

D

- Data Sheet 29
- Debounce Time. See Zone Speed
- Delay after pager message 11
- Delete Telephone and Pager Numbers 22
- Deleting Telephone & Pager Numbers 22
- Diagram, Installation 4
- Dialer Mode 7
- Dialing Method 10
- Dialing Options 10
 - Dialing Method 10*
 - Post Pager Message Delay 11*
 - Pulse Options 11*

Redials 10

- Dial-out List 8

F

- Features 1

G

- Glossary 2
- Glossary of Terms 2

I

- Idle State 13
- Indicators, LED 6
- input terminals 5
- Input, Zone Terminals 5
- Installation 3
- Installer PIN 15
- Installer Programming Mode 8
 - Answering Options 16*
 - Call Progress Options 18*
 - Dialing Options 10*
 - PIN Options 15*
 - Voice Message Options 11*
 - Zone Options 13*
- Introduction 1

K

- Kiss Off Options 12
- Kiss-Off Options 12

L

- LED Indicators 6
 - OK LED 6*
 - Pulse LED 6*
- Length of voice messages 12
- Local Connection Code 17
- Local Connection Options 17

Local Reset. See Zone 4 Mode
Location & Mounting 3

M

Message Length, Voice 12
Message Options, Voice 11
Message Repeats, Voice 12
Messages, Record 23
Mounting Location 3

N

No Dial Tone Action 18

O

Opening Menu, User's 18
Operation, Basic 6
Override Answering Machine 16

P

Pager Messages 24
Pager Messages Recording 23
Pager Number 7
Pager Numbers, Deleting 22
ParaVox Installation Diagram 4
PGMs 5
PIN Options 15
 Change Installer PIN 15
 Installer PIN Length 15
 User PIN Length 15
PIN, Change 25
Post Pager Message Delay 11
Power Connections 3
Program Output Labels 24
Program User PIN 25
Programmable Outputs 5
Programmable Outputs (PGM) 5
Programming Data Sheet 29
Programming Mode
 Installer 8
 User 19

Pulse Options 11

R

Record Messages 23
Record Telephone Numbers 21
Record Voice or Page Messages 23
Recording Messages
 Pager Messages 24
 Program Output Labels 24
 Voice Messages 24
Recording Voice/Pager Messages 23
Redials 10
Repeat voice messages 12
reset 6
Reset System 6
Rings Before Answering 16

S

Sending Test Messages 28
Set Installer PIN Length 15
Set User PIN Length 15
Specifications 2
specifications 2
Standby Mode 7
Store Telephone Numbers 21
System Features 1
System Reset 6

T

Technical Specifications 2
Telephone & Pager Numbers, Delete 22
Telephone Line Connections 3
Telephone Line Monitoring 17
Telephone Line Monitoring (TLM) 17
Telephone Number Assignment 27
Telephone Numbers, Deleting 22
Telephone Numbers, Store 21
Telephone Numbers, Storing 21
Terminals, Zone Input 5
Test Message Sending 28
TLM 17

U

- User PIN, Change 25
- User PIN, Changing 25
- User Programming Mode 19
- User's Opening Menu 18
- User's Programming Mode
 - Change User PIN 25*
 - Deleting Pager Numbers 22*
 - Deleting Telephone Numbers 22*
 - Recording Messages 23*
 - Store Telephone Numbers 21*
 - Telephone Number Assignment 27*
 - Test Message Sending 28*

V

- Voice Message Length 12
- Voice Message Number 7
- Voice Message Options 11
 - Kiss Off Options 12*
 - Message Length 12*
 - Message Repeats 12*
- Voice Message Recording 23
- Voice Message Repeats 12
- Voice Messages 24

Z

- Zone 4 Mode 14
- Zone 4 Special Defaults 14
- Zone Input Terminals 5
- Zone Options 13
 - Idle State 13*
 - Zone 4 Mode 14*
 - Zone Speed 14*
 - Zone Type 13*
- Zone Speed 14
- Zone Type 13

WARRANTY

Paradox Security Systems Ltd. ("Seller") warrants its products to be free from defects in materials and workmanship under normal use for a period of one year. Except as specifically stated herein, all express or implied warranties whatsoever, statutory or otherwise, including without limitation, any implied warranty of merchantability and fitness for a particular purpose, are expressly excluded. Because Seller does not install or connect the products and because the products may be used in conjunction with products not manufactured by Seller, Seller cannot guarantee the performance of the security system and shall not be responsible for circumstances resulting from the product's inability to operate. Seller obligation and liability under this warranty is expressly limited to repairing or replacing, at Seller's option, any product not meeting the specifications. Returns must include proof of purchase and be within the warranty period. In no event shall the Seller be liable to the buyer or any other person for any loss or damages whether direct or indirect or consequential or incidental, including without limitation, any damages for lost profits stolen goods, or claims by any other party, caused by defective goods or otherwise arising from the improper, incorrect or otherwise faulty installation or use of the merchandise sold.

Notwithstanding the preceding paragraph, the Seller's maximum liability will be strictly limited to the purchase price of the defective product. Your use of this product signifies your acceptance of this warranty.

BEWARE: Dealers, installers and/or others selling the product are not authorized to modify this warranty or make additional warranties that are binding on the Seller.

© 1998-2006 Paradox Security Systems Ltd. All rights reserved. Specifications may change without prior notice. One or more of the following US patents may apply: 6215399, 6111256, 5751803, 5721542, 5287111, 5119069, 5077549, 5920259 and 5886632. Canadian and international patents may also apply.

Limitations of Alarm Systems

It must be understood that while your Paradox alarm system is highly advanced and secure, it does not offer any guaranteed protection against burglary, fire or other emergency (fire and emergency options are only available on certain Paradox models). This is due to a number of reasons, including but not limited to inadequate or improper installation/positioning, sensor limitations, battery performance, wireless signal interruption, inadequate maintenance or the potential for the system or telephone lines to be compromised or circumvented. As a result, Paradox does not represent that the alarm system will prevent personal injury or property damage, or in all cases provide adequate warning or protection. Your security system should therefore be considered as one of many tools available to reduce risk and/or damage of burglary, fire or other emergencies, such other tools include but are not limited to insurance coverage, fire prevention and extinguish devices, and sprinkler systems. We also strongly recommend that you regularly maintain your security systems and stay aware of new and improved Paradox products and developments.

ParaVox is a trademark or registered trademark of Paradox Security Systems Ltd. or its affiliates in Canada, the United States and/or other countries.

For technical support in Canada or the U.S., call 1-800-791-1919 Monday to Friday from 8:00 a.m. to 8:00 p.m. EST. For technical support outside Canada and the U.S., call 00-1-450-491-7444, Monday to Friday from 8:00 a.m. to 8:00 p.m. EST. Please feel free to visit our website at paradox.com.



paradox.com