



S P E C T R A™

1728, 1728EX, 1738 AND 1738EX

SYSTEM PROGRAMMING GUIDE

Software Version 2.0

DEFAULT INSTALLER CODE

000000 (see section [281] on pag e17)

DEFAULT SYSTEM MASTER CODE

123456 (see section [301] on pag e17)

HOW DO I ENTER PROGRAMMING MODE?

STEP 1: Press [ENTER]

STEP 2: Enter your [INSTALLER CODE]

STEP 3: Enter 3-digit [SECTION] you wish to program

STEP 4: Enter required [DATA]

DECIMAL AND HEXADECIMAL PROGRAMMING TABLE

Value or Action	What Do I Press?	What Do I See?		
		10-Zone LED	16-Zone LED	LCD
Values 1 to 9	[1] to [9]	[1] to [9]	[1] to [9]	[1] to [9]
A (hexa only)	[0]	[0 (10)]	[10]	0
B (hexa only)	[STAY]	[STAY]	[11]	B
C (hexa only)	[BYP]	[BYP]	[12]	C
D (hexa only)	[MEM]	[MEM]	[13]	D
E (hexa only)	[TBL] / [TRBL]	[TBL]	[14]	E
F (hexa only)	[PG] / [FNC1]	[PG]	[15]	F
Exit Without Saving	[CLEAR]	[ENTER] flashes	[ARM1] & [STAY1] flash	"SECTION []"
Erase Current Digit	[FORCE]	Displays next digit or next section		
Save Data (hexa only)	[ENTER]	Advances to the next section		

TROUBLE DISPLAY

Press the [TBL] or [TRBL] key to view the *Trouble Display*. Please note that the keypad can be programmed to emit a BEEP every 5 seconds whenever a new trouble condition has occurred. Press the [TBL] or [TRBL] key to stop the beeping.

[1] - No Battery or Low Battery

[2] - Wireless Transmitter Low Battery

[3] - Power Failure

[4] - Bell Output Disconnected

[5] - Maximum Bell Current

[6] - Maximum Auxiliary Current

[7] - Communicator Report Failure

[8] - Timer Loss**

[9] - Tamper or Zone Wiring Failure*

[10] - Telephone Line Monitoring Failure

[11]/[STAY] - Fire Loop Trouble*

[12]/[BYP] - Module Loss

[13]/[MEM] - Wireless Transmitter Supervision Loss*

[16]/[FORCE] and [TBL]/[TRBL] flashes - Keypad Fault

* press the illuminated key ([9], [STAY] or [MEM]) to view which zones are causing the trouble. Enter the Installer Code to clear Tamper troubles.

** press [8] to re-program the time.

TABLE OF CONTENTS

DEFAULT INSTALLER CODE	1
DEFAULT SYSTEM MASTER CODE	1
HOW DO I ENTER PROGRAMMING MODE?	1
DECIMAL AND HEXADECIMAL PROGRAMMING TABLE	1
TROUBLE DISPLAY	1
DATA DISPLAY MODE (LED KEYPADS ONLY).....	4
ZONE PROGRAMMING	4
HOW DO I PROGRAM THE ZONES?	5
SYSTEM TIMERS	6
PROGRAMMABLE OUTPUTS	7
SYSTEM OPTIONS.....	10
COMMUNICATION SETTINGS	14
REPORT CODES.....	15
SYSTEM SETTINGS.....	17
USER CODE OPTIONS.....	17
REPROGRAM ALL MODULES	18
PARADOX MEMORY KEY (PMC-3).....	18
4-OUTPUT BUS MODULE V1.0	19
PRINTER BUS MODULE V1.1.....	20
VOICE-ASSISTED ARM/DISARM BUS MODULE V1.0	22
WIRELESS BUS MODULES.....	23
ZONE EXPANSION BUS MODULES	27
USER OPERATION	28
APPENDIX A - ADEMCO CID REPORT CODE LIST (PROG.)	30
APPENDIX B - ADEMCO CID REPORT CODE LIST (ALL CODES).....	31
BUS MODULE CONNECTIONS	33
HARDWARE CONNECTIONS	38
NOTES	42

DATA DISPLAY MODE (LED Keypads Only)

View the section's programming one digit at a time. Does not function with sections using *Feature Select Programming*.

To access the *Data Display Mode*, press the [ENTER] key after entering a section and before entering any data. The three LEDs as indicated below will begin to flash indicating that you are in the *Data Display Mode*.

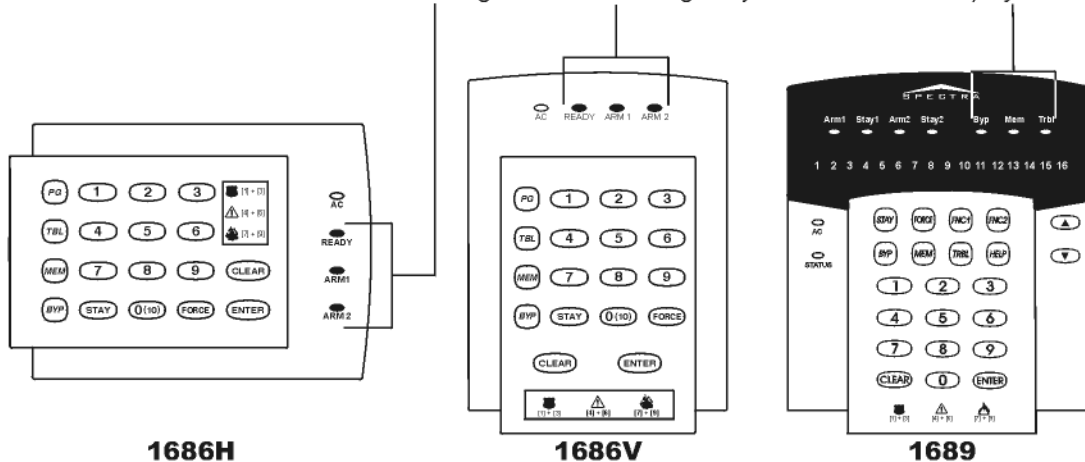

Each time the [ENTER] key is pressed, the keypad will display the next digit in the current section and will continue through all the following sections one digit at a time without changing the programmed values. Not available for sections using the *Multiple Feature Select Method*. Press the [CLEAR] key at any time to exit the *Data Display Mode*.

ZONE PROGRAMMING

When programming zones, the zone assignments are dependent on where the detection devices in the system are connected. **Do not assign inputs from different modules to the same expansion input.** In 1728/EX control panel installations that require using mostly the expansion inputs, refer to Reassign Zones to Expansion Inputs (see section [126] option [8]).

Zone Recognition Table

Device connected to which input?	1728/EX	1728	1728/EX	1728	1738/EX	1738	1738/EX	1738
	NO ATZ	WITH ATZ	NO ATZ	WITH ATZ	NO ATZ	WITH ATZ	NO ATZ	WITH ATZ
Control Panel								
Input 1 =	Zone 1	Zone 1 & 6	Zone 1	Zone 1 & 6	Zone 1	Zone 1 & 8	Zone 1	Zone 1 & 8
Input 2 =	Zone 2	Zone 2 & 7	Zone 2	Zone 2 & 7	Zone 2	Zone 2 & 9	Zone 2	Zone 2 & 9
Input 3 =	Zone 3	Zone 3 & 8	Zone 3	Zone 3 & 8	Zone 3	Zone 3 & 10	Zone 3	Zone 3 & 10
Input 4 =	Zone 4	Zone 4 & 9	Zone 4	Zone 4 & 9	Zone 4	Zone 4 & 11	Zone 4	Zone 4 & 11
Input 5 =	Zone 5	Zone 5 & 10	Zone 5	Zone 5 & 10	Zone 5	Zone 5 & 12	Zone 5	Zone 5 & 12
Input 6 =	N/A	N/A	N/A	N/A	Zone 6	Zone 6 & 13	Zone 6	Zone 6 & 13
Input 7 =	N/A	N/A	N/A	N/A	Zone 7	Zone 7 & 14	Zone 7	Zone 7 & 14
Keypad								
Zone 1 =	Zone 6	Zone 11	Zone 6	Zone 11	Zone 8	Zone 15	Zone 8	Zone 15
Zone 2 =	Zone 7	Zone 12	N/A	N/A	Zone 9	Zone 16	N/A	N/A
Expansion								
Input 1 =	Zone 8	Zone 13	Zone 7	Zone 12	Zone 10	N/A	Zone 9	Zone 16
Input 2 =	Zone 9	Zone 14	Zone 8	Zone 13	Zone 11	N/A	Zone 10	N/A
Input 3 =	Zone 10	Zone 15	Zone 9	Zone 14	Zone 12	N/A	Zone 11	N/A
Input 4 =	Zone 11	Zone 16	Zone 10	Zone 15	Zone 13	N/A	Zone 12	N/A
Input 5 =	Zone 12	N/A	Zone 11	Zone 16	Zone 14	N/A	Zone 13	N/A
Input 6 =	Zone 13	N/A	Zone 12	N/A	Zone 15	N/A	Zone 14	N/A
Input 7 =	Zone 14	N/A	Zone 13	N/A	Zone 16	N/A	Zone 15	N/A
Input 8 =	Zone 15	N/A	Zone 14	N/A	N/A	N/A	Zone 16	N/A

HOW DO I PROGRAM THE ZONES?

- STEP 1: Press the [ENTER] key
 STEP 2: Enter the [INSTALLER CODE] (Default: 000000)
 STEP 3: Enter 3-digit [SECTION]
 STEP 4: Enter one digit from the **Zone Definition** table
 STEP 5: Enter one digit from the **Partition Assignment** table
 STEP 6: Select one or more options from the **Zone Options** table
 STEP 7: Press the [ENTER] key

ZONE DEFINITION	
Empty	- Zone Disabled
1	- Entry Delay 1
2	- Entry Delay 2
3	- Follow
4	- Instant
5	- 24Hr. Burglary
6	- 24Hr. Buzzer
Additional definitions for on-board terminals:	
7	- Keyswitch
8	- Fire 24 Hr.
9	- Delayed Fire 24 Hr.

PARTITION ASSIGNMENT	
Empty	- Zone Disabled
1	- Partition 1
2	- Partition 2
3	- Both Partitions

ZONE OPTIONS	
1	- Auto Zone Shutdown
2	- Bypassable Zone
3	- Stay Zone
4 - 5 - <u>Zone Alarm Type</u>	
off off	Audible alarm (steady)
off on	Audible alarm (pulsed)
on off	Silent alarm
on on	Generates a report only
6	- Intellizone
7	- Delay alarm transmission
8	- Force Zone
KEYSWITCH OPTIONS	
1	- off = Maintained on = Momentary
2	- off = Regular Arm on = Stay Arm



[FORCE] key = empty

First Digit

Second Digit

Section	Description	Zone Definition	Partition Assignment	Zone Options
[001] = Zone 01:	_____	_____	_____	1 2 3 4 5 6 7 8
[002] = Zone 02:	_____	_____	_____	1 2 3 4 5 6 7 8
[003] = Zone 03:	_____	_____	_____	1 2 3 4 5 6 7 8
[004] = Zone 04:	_____	_____	_____	1 2 3 4 5 6 7 8
[005] = Zone 05:	_____	_____	_____	1 2 3 4 5 6 7 8
[006] = Zone 06:	_____	_____	_____	1 2 3 4 5 6 7 8
[007] = Zone 07:	_____	_____	_____	1 2 3 4 5 6 7 8
[008] = Zone 08:	_____	_____	_____	1 2 3 4 5 6 7 8
[009] = Zone 09:	_____	_____	_____	1 2 3 4 5 6 7 8
[010] = Zone 10:	_____	_____	_____	1 2 3 4 5 6 7 8
[011] = Zone 11:	_____	_____	_____	1 2 3 4 5 6 7 8
[012] = Zone 12:	_____	_____	_____	1 2 3 4 5 6 7 8
[013] = Zone 13:	_____	_____	_____	1 2 3 4 5 6 7 8
[014] = Zone 14:	_____	_____	_____	1 2 3 4 5 6 7 8
[015] = Zone 15:	_____	_____	_____	1 2 3 4 5 6 7 8
[016] = Zone 16:	_____	_____	_____	1 2 3 4 5 6 7 8
Defaults =		Empty	Partition 1	1 and 2 ON



Only the control panel's on-board inputs can be defined as a Fire, Delayed Fire or a Keyswitch zone. In the 1728 and 1728EX the on-board zones are zones 01 to 05 and in the 1738 and 1738EX the on-board zones are zones 01 to 07.

SYSTEM TIMERS

Section #	Decimal Value (000 to 255)	Description	Default
[050]	___/___/___ x 10 msec.	ZONE SPEED (ZONE 1)	600 msec.
[051]	___/___/___ x 10 msec.	ZONE SPEED (ZONE 2)	600 msec.
[052]	___/___/___ x 10 msec.	ZONE SPEED (ZONE 3)	600 msec.
[053]	___/___/___ x 10 msec.	ZONE SPEED (ZONE 4)	600 msec.
[054]	___/___/___ x 10 msec.	ZONE SPEED (ZONE 5)	600 msec.
[055]	___/___/___ x 10 msec.	ZONE SPEED (ZONE 6)	600 msec.
[056]	___/___/___ x 10 msec.	ZONE SPEED (ZONE 7)	600 msec.
[057]	___/___/___ x 10 msec.	ZONE SPEED (ZONE 8)	600 msec.
[058]	___/___/___ x 10 msec.	ZONE SPEED (ZONE 9)	600 msec.
[059]	___/___/___ x 10 msec.	ZONE SPEED (ZONE 10)	600 msec.
[060]	___/___/___ x 10 msec.	ZONE SPEED (ZONE 11)	600 msec.
[061]	___/___/___ x 10 msec.	ZONE SPEED (ZONE 12)	600 msec.
[062]	___/___/___ x 10 msec.	ZONE SPEED (ZONE 13)	600 msec.
[063]	___/___/___ x 10 msec.	ZONE SPEED (ZONE 14)	600 msec.
[064]	___/___/___ x 10 msec.	ZONE SPEED (ZONE 15)	600 msec.
[065]	___/___/___ x 10 msec.	ZONE SPEED (ZONE 16)	600 msec.
NOTE: If ATZ is enabled (section [132] option [5]), do not set the Zone Speed to less than 50msec. as this may cause false alarms.			
[066]	___/___/___ seconds (000 = follow Deactivation Event)	PGM1 TIMER	5 sec.
[067]	___/___/___ seconds (000 = follow Deactivation Event)	PGM2 TIMER (FOR 1738 & 1738EX ONLY)	5 sec.
[068]	___/___/___ seconds (000 = follow Deactivation Event)	GLOBAL PGM TIMER	5 sec.
[069]	___/___/___ seconds	ENTRY DELAY 1	45 sec.
[070]	___/___/___ seconds	ENTRY DELAY 2	45 sec.
[071]	___/___/___ seconds	EXIT DELAY 1	30 sec.
[072]	___/___/___ seconds	EXIT DELAY 2	30 sec.
[073]	___/___/___ minutes (000 = no bell on alarm)	BELL CUT-OFF TIMER (PARTITION 1)	4 min.
[074]	___/___/___ minutes (000 = no bell on alarm)	BELL CUT-OFF TIMER (PARTITION 2)	4 min.
[075]	___/___/___ x 15 minutes (000 = disabled)	NO MOVEMENT TIMER (PARTITION 1)	Disabled
[076]	___/___/___ x 15 minutes (000 = disabled)	NO MOVEMENT TIMER (PARTITION 2)	Disabled
[077]	___/___/___ seconds (minimum 10 sec.)	ANSWERING MACHINE OVERRIDE DELAY	Disabled
[078]	___/___/___ (000 = no answer, maximum = 15 rings)	NUMBER OF RINGS	8 rings
[079]	___/___/___ x 2 sec. (minimum 32 sec.)	TLM FAIL TIMER	32 sec.
[080]	___/___/___ seconds	DELAY ALARM TRANSMISSION	Disabled
[081]	___/___/___ (000 = 16, maximum = 16)	MAXIMUM DIALING ATTEMPTS	8 attempts
[082]	___/___/___ seconds	DELAY BETWEEN ATTEMPTS	20 sec.
[083]	___/___/___ seconds	PAGER DELAY	5 sec.
[084]	___/___/___ seconds (minimum 10 sec.)	INTELLIZONE DELAY	48 sec.
[085]	___/___/___ seconds	RECENT CLOSING DELAY	No delay
[086]	___/___/___ minutes	POWER FAILURE REPORT DELAY	15 min.
[087]	___/___/___ days (000 = disabled)	AUTO TEST REPORT	Disabled
[088]	___/___/___ 000 to 127 = +1 to +127 seconds 128 to 255 = -1 to -127 seconds	CLOCK ADJUST	Disabled
[089]	___/___/___ (000 = disabled, maximum = 15)	AUTO ZONE SHUTDOWN COUNTER	5
[090]	___/___/___ minutes (000 = disabled)	RECYCLE ALARM DELAY	Disabled
[091]	___/___/___ (000 = disabled)	RECYCLE ALARM COUNTER	Disabled
[092]	___/___/___ attempts before locking (000 = disabled)	KEYPAD LOCKOUT	Disabled
[093]	___/___/___ minutes (000 = disabled)	KEYPAD LOCKOUT DELAY	Disabled
[094]	___/___/___ seconds (000 = disabled)	PANIC LOCKOUT TIMER	Disabled
[110]	___/___ : ___/___ hours (00 to 23) : minutes (00 to 59)	AUTO TEST REPORT (TIME OF DAY)	Disabled
[111]	___/___ : ___/___ hours (00 to 23) : minutes (00 to 59)	AUTO-ARM TIME (PARTITION 1)	Disabled
[112]	___/___ : ___/___ hours (00 to 23) : minutes (00 to 59)	AUTO-ARM TIME (PARTITION 2)	Disabled

PROGRAMMABLE OUTPUTS

Each PGM Deactivation event can be used as another start (activation) event if their respective PGM timer (see sections [066] to [068]) is programmed with a value other than 000.

Example: section [120] = 05 03 02: this means PGM1 will activate whenever partition 2 is Stay Armed.

Section #		Event Group #	Sub-Group #	Partition #	
[120]	PGM 1 PGM Activation Event	___/___	___/___	___/___	<div style="border: 1px solid black; padding: 5px;"> 01 = Partition 1 02 = Partition 2 99 = Any Partition <i>The Sub-Groups preceded by "(Partition 1)" cannot be assigned to activate Partition 2.</i> </div>
[121]	PGM 1 PGM Deactivation Event	___/___	___/___	___/___	
	<i>PGM2 for 1738 and 1738EX only:</i>				
[122]	PGM 2 PGM Activation Event	___/___	___/___	___/___	
[123]	PGM 2 PGM Deactivation Event	___/___	___/___	___/___	
[124]	Global PGM Activation Event	___/___	___/___	___/___	
[125]	Global PGM Deactivation Event <i>Used to activate PGMs on expansion modules & LCD keypads.</i>	___/___	___/___	___/___	

Event Group #	Sub-Group #
00 = Zone OK	01 to 16 = Zones 1 to 16 99 = Any Zone
01 = Zone Open	01 to 16 = Zones 1 to 16 99 = Any Zone
02 = Partition Status	00 = System not ready (<i>Partition 1 only</i>) 01 = System ready (<i>Partition 1 only</i>) 02 = Steady Alarm in Partition 03 = Pulsed Alarm in Partition 04 = Pulsed or Steady Alarm in Partition 05 = Alarm in Partition Restored 06 = Bell Squawk Activated (<i>Partition 1 only</i>) 07 = Bell Squawk Deactivated (<i>Partition 1 only</i>) 08 = Ground start (<i>Partition 1 only</i>) 09 = Disarm Partition 10 = Arm Partition 11 = Entry Delay (breach when system is armed) 99 = Any Sub-Group
05 = Non-Reportable Events	00 = Telephone Line Trouble (<i>Partition 1 only</i>) 01 = [PG] or [FNC1] key was pressed (<i>Partition 1 only</i>) 02 = Instant Arming 03 = Stay Arming 04 = Force Arming 05 = Fast Exit (Force & Regular Only) 06 = PC Fail to Communicate (<i>Partition 1 only</i>) 07 = Midnight (<i>Partition 1 only</i>) 99 = Any Sub-Group (<i>Partition 1 only, except 02 to 05</i>)
06 = Arm/Disarm with Remote Control	01 to 08 = Remote Controls 1 to 8 99 = Any Remote Control
07 = Button Pressed on Remote <i>(see button option "B" on page25)</i>	01 to 08 = Remote Controls 1 to 8 99 = Any Remote Control
08 = Button Pressed on Remote <i>(see button option "C" on page25)</i>	01 to 08 = Remote Controls 1 to 8 99 = Any Remote Control

Event Group #	Sub-Group #
09 = Button Pressed on Remote <i>(see button option "D" on page 25)</i>	01 to 08 = Remote Controls 1 to 8 99 = Any Remote Control
10 = Bypass Programming	01 to 48 = User Code Numbers 001 to 048 99 = Any User Code
11 = User Activated PGM	01 to 48 = User Code Numbers 001 to 048 <i>(Partition 1 only)</i> 99 = Any User Code
12 = Zone with Delay Transmission Option Enabled is Breached	01 to 16 = Zones 1 to 16 99 = Any Zone
13 = Arm with User Code	01 to 48 = User Code Numbers 001 to 048 99 = Any User Code
14 = Special Arm	00 = Auto Arming (timed/no movement) 01 = Late to Close (Auto-Arming failed) 02 = No Movement Auto-Arming 03 = Partial Arming (Stay, Force, Instant, Bypass) 04 = One-Touch Arming 05 = Arm with WinLoad Software 99 = Any Sub-Group
15 = Disarm with User Code	01 to 48 = User Code Numbers 001 to 048 99 = Any User Code
16 = Disarm After Alarm w/ User Code	01 to 48 = User Code Numbers 001 to 048 99 = Any User Code
17 = Cancel Alarm with User Code	01 to 48 = User Code Numbers 001 to 048 99 = Any User Code
18 = Special Disarm	00 = Cancel Auto Arm (timed/no movement) 01 = Disarm with WinLoad Software 02 = Disarm after alarm with WinLoad Software 03 = Cancel Alarm with WinLoad Software 99 = Any Sub-Group
19 = Zone Bypassed on Arming	01 to 16 = Zones 1 to 16 99 = Any Zone
20 = Zone in Alarm	01 to 16 = Zones 1 to 16 99 = Any Zone
21 = Fire Alarm	1728/EX: 01 to 05 = Zones 1 to 5 (on-board inputs) 1738/EX: 01 to 07 = Zones 1 to 7 (on-board inputs) 99 = Any Zone
22 = Zone Alarm Restore	01 to 16 = Zones 1 to 16 99 = Any Zone
23 = Fire Alarm Restore	1728/EX: 01 to 05 = Zones 1 to 5 (on-board inputs) 1738/EX: 01 to 07 = Zones 1 to 7 (on-board inputs) 99 = Any Zone
24 = Special Alarm	00 = Emergency Panic 01 = Auxiliary Panic 02 = Fire Panic 03 = Recent Closing 04 = Auto Zone Shutdown 05 = Duress Alarm 06 = Keypad Lockout 99 = Any Sub-Group
25 = Auto Zone Shutdown	01 to 16 = Zones 1 to 16 99 = Any Zone
26 = Zone Tamper	01 to 16 = Zones 1 to 16 99 = Any Zone
27 = Zone Tamper Restore	01 to 16 = Zones 1 to 16 99 = Any Zone

Event Group #	Sub-Group #
28 = System Trouble	01 = AC Loss: only after <i>Power Failure Delay</i> has elapsed (<i>Partition 1 only</i>) 02 = Battery Failure (<i>Partition 1 only</i>) 03 = Auxiliary current overload (<i>Partition 1 only</i>) 04 = Bell current overload (<i>Partition 1 only</i>) 05 = Bell disconnected (<i>Partition 1 only</i>) 06 = Timer Loss (<i>Partition 1 only</i>) 07 = Fire Loop Trouble (<i>Partition 1 only</i>) 08 = Future Use 09 = Module Fault (<i>Partition 1 only</i>) 10 = Printer Fault (<i>Partition 1 only</i>) 11 = Fail to Communicate (<i>Partition 1 only</i>) 99 = Any Sub-Group (<i>Partition 1 only</i>)
29 = System Trouble Restore	00 = TLM restore (<i>Partition 1 only</i>) 01 = AC Loss restore (<i>Partition 1 only</i>) 02 = Battery Failure restore (<i>Partition 1 only</i>) 03 = Auxiliary current overload restore (<i>Partition 1 only</i>) 04 = Bell current overload restore (<i>Partition 1 only</i>) 05 = Bell disconnected restore (<i>Partition 1 only</i>) 06 = Timer Programmed (<i>Partition 1 only</i>) 07 = Fire Loop Trouble restore (<i>Partition 1 only</i>) 08 = Future Use 09 = Module Fault restore (<i>Partition 1 only</i>) 10 = Printer Fault restore (<i>Partition 1 only</i>) 11 = Fail to Communicate restore (<i>Partition 1 only</i>) 99 = Any Trouble Restore (<i>Partition 1 only</i>)
30 = Special Reporting	00 = System Power Up (<i>Partition 1 only</i>) 01 = Test Report (<i>Partition 1 only</i>) 02 = WinLoad Software Access (<i>Partition 1 only</i>) 03 = WinLoad Software Access finished (<i>Partition 1 only</i>) 04 = Installer enters programming mode (<i>Partition 1 only</i>) 05 = Installer exits programming mode (<i>Partition 1 only</i>) 99 = Any Sub-Group (<i>Partition 1 only</i>)
31 = Wireless Transmitter Supervision Loss	01 to 16 = Zones 1 to 16 99 = Any Zone
32 = Wireless Transmitter Supervision Loss Restore	01 to 16 = Zones 1 to 16 99 = Any Zone
33 = Arming with a Keyswitch	1728/EX: 01 to 05 = Zones 1 to 5 (on-board inputs) 1738/EX: 01 to 07 = Zones 1 to 7 (on-board inputs) 99 = Any Zone
34 = Disarming with a Keyswitch	1728/EX: 01 to 05 = Zones 1 to 5 (on-board inputs) 1738/EX: 01 to 07 = Zones 1 to 7 (on-board inputs) 99 = Any Zone
35 = Disarm after Alarm with a Keyswitch	1728/EX: 01 to 05 = Zones 1 to 5 (on-board inputs) 1738/EX: 01 to 07 = Zones 1 to 7 (on-board inputs) 99 = Any Zone
36 = Cancel Alarm with a Keyswitch	1728/EX: 01 to 05 = Zones 1 to 5 (on-board inputs) 1738/EX: 01 to 07 = Zones 1 to 7 (on-board inputs) 99 = Any Zone
37 = Wireless Transmitter Low Battery	01 to 16 = Zones 1 to 16 99 = Any Zone
38 = Wireless Transmitter Low Battery Restore	01 to 16 = Zones 1 to 16 99 = Any Zone

Event Group #	Sub-Group #	Partition #
80 = PGM follows Clock (APR3-PGM4 only)	HH = hour according to 24hr. clock	MM = minutes according to 24hr. clock

SYSTEM OPTIONS

Bold = Default Setting

SECTION [126]: General Options

Option	OFF	ON
[1] <i>Confidential Mode</i>	<input type="checkbox"/> Disabled	<input type="checkbox"/> Enabled
[2] <i>To Exit Confidential Mode</i>	<input type="checkbox"/> Enter Access Code	<input type="checkbox"/> Press a Key
[3] <i>Confidential Mode Timer</i>	<input type="checkbox"/> 2 minutes	<input type="checkbox"/> 5 seconds
[4] <i>PGM1 Normal State</i>	<input type="checkbox"/> Normally Open (N.O.)	<input type="checkbox"/> Normally Closed (N.C.)
[5] <i>PGM2 Normal State (1738 and 1738EX only)</i>	<input type="checkbox"/> Normally Open (N.O.)	<input type="checkbox"/> Normally Closed (N.C.)
[6] <i>Global PGM Normal State</i>	<input type="checkbox"/> Normally Open (N.O.)	<input type="checkbox"/> Normally Closed (N.C.)
[7] <i>Reassign Keypad Zone 2</i>	<input type="checkbox"/> Disabled	<input type="checkbox"/> Enabled
[8] <i>Reassign Zones to Expansion Inputs* (1728 and 1728EX only)</i>	<input type="checkbox"/> Disabled	<input type="checkbox"/> Enabled

* *Reassign Zones to Expansion Inputs* changes the zone numbering to increase the number of expansion inputs that can be displayed on 10-Zone LED Keypads. Refer to 1728, 1728EX, 1738 and 1738EX Reference & Installation Manual for details.

SECTION [127]: General Options

Option	OFF	ON
[1] <i>Partitioning</i>	<input type="checkbox"/> Disabled	<input type="checkbox"/> Enabled
[2] <i>Access Code Length</i>	<input type="checkbox"/> 6-digits	<input type="checkbox"/> 4-digits
[3] <i>Keypad Audible Trouble Warning</i>	<input type="checkbox"/> Disabled	<input type="checkbox"/> Enabled
[4] <i>Lock System Master Code</i>	<input type="checkbox"/> Disabled	<input type="checkbox"/> Enabled
[5] <i>Battery Charge Current</i>	<input type="checkbox"/> 350mA	<input type="checkbox"/> 700mA
[6] <i>User Code 048 is a Duress Code</i>	<input type="checkbox"/> Disabled	<input type="checkbox"/> Enabled
[7] <i>Alarm Relay follows (1738 and 1738EX only)</i>	<input type="checkbox"/> Bell Output	<input type="checkbox"/> Global PGM
[8] <i>Future Use</i>	<input type="checkbox"/> N/A	<input type="checkbox"/> N/A

SECTION [128]: General Options

Option	OFF	ON
[1] <i>Panic 1: Keys [1] & [3]</i>	<input type="checkbox"/> Disabled	<input type="checkbox"/> Enabled
[2] <i>Panic 2: Keys [4] & [6]</i>	<input type="checkbox"/> Disabled	<input type="checkbox"/> Enabled
[3] <i>Panic 3: Keys [7] & [9]</i>	<input type="checkbox"/> Disabled	<input type="checkbox"/> Enabled
[4] <i>Panic 1: Silent or Audible</i>	<input type="checkbox"/> Silent	<input type="checkbox"/> Audible
[5] <i>Panic 2: Silent or Audible</i>	<input type="checkbox"/> Silent	<input type="checkbox"/> Audible
[6] <i>Panic 3: Silent or Fire</i>	<input type="checkbox"/> Silent	<input type="checkbox"/> Fire
[7] <i>Keypad 1 Tamper Supervision</i>	<input type="checkbox"/> Disabled	<input type="checkbox"/> Enabled
[8] <i>Keypad 2 Tamper Supervision</i>	<input type="checkbox"/> Disabled	<input type="checkbox"/> Enabled

SECTION [129]: General Options

Option	OFF	ON
[1] <i>PGM2 Output Activation Option *</i>	<input type="checkbox"/> Steady	<input type="checkbox"/> Pulse (flash)
[2] <i>PGM2 Pulse Once Every 30sec if System Armed *</i>	<input type="checkbox"/> Disabled	<input type="checkbox"/> Enabled
[3] <i>PGM2 Pulse On Arm, Twice On Disarm *</i>	<input type="checkbox"/> Disabled	<input type="checkbox"/> Enabled
[4] <i>ZX4 & ZX8 Zone Expansion Module Supervision</i>	<input type="checkbox"/> Disabled	<input type="checkbox"/> Enabled
[5] <i>Wireless Module Supervision</i>	<input type="checkbox"/> Disabled	<input type="checkbox"/> Enabled
[6] <i>Wireless Module Low Battery Supervision</i>	<input type="checkbox"/> Disabled	<input type="checkbox"/> Enabled
[7] <i>4-Output Bus Module Supervision (APR3-PGM4)</i>	<input type="checkbox"/> Disabled	<input type="checkbox"/> Enabled
[8] <i>Printer Module Supervision (APR3-PRT1)</i>	<input type="checkbox"/> Disabled	<input type="checkbox"/> Enabled

* for 1738 and 1738EX only

Bold = Default Setting

SECTION [130]: Arming/Disarming Options

Option	OFF	ON
[1] <i>One-Touch Regular Arming</i>	<input type="checkbox"/> Disabled	<input type="checkbox"/> Enabled
[2] <i>One-Touch Stay Arming</i>	<input type="checkbox"/> Disabled	<input type="checkbox"/> Enabled
[3] <i>One-Touch Force Arming</i>	<input type="checkbox"/> Disabled	<input type="checkbox"/> Enabled
[4] <i>One-Touch Bypass Programming</i>	<input type="checkbox"/> Disabled	<input type="checkbox"/> Enabled
[5] <i>Restrict Arming on Battery Failure</i>	<input type="checkbox"/> Disabled	<input type="checkbox"/> Enabled
[6] <i>Restrict Arming on Tamper Failure</i>	<input type="checkbox"/> Disabled	<input type="checkbox"/> Enabled
[7] <i>Bell Squawk on Arm/Disarm with Keypad</i>	<input type="checkbox"/> Disabled	<input type="checkbox"/> Enabled
[8] <i>Beep on Exit Delay</i>	<input type="checkbox"/> Disabled	<input type="checkbox"/> Enabled

SECTION [131]: Arming/Disarming Options

Option	OFF	ON
[1] <i>Report Disarming</i>	<input type="checkbox"/> Always	<input type="checkbox"/> Only after alarm
[2] <i>Regular Arming Switches to Force Arming</i>	<input type="checkbox"/> Disabled	<input type="checkbox"/> Enabled
[3] <i>Bell Squawk on Arm/Disarm with Remote Control (must be enabled for UL installations)</i>	<input type="checkbox"/> Disabled	<input type="checkbox"/> Enabled
[4] <i>No Exit Delay When Arming with a Remote Control</i>	<input type="checkbox"/> Disabled	<input type="checkbox"/> Enabled
[5] <i>No Exit Delay Beeps and No Bell Squawk When Stay Arming</i>	<input type="checkbox"/> Disabled	<input type="checkbox"/> Enabled
[6] <i>Restrict Arming On Wireless Transmitter Supervision Loss</i>	<input type="checkbox"/> Disabled	<input type="checkbox"/> Enabled
[7] <i>Generate Supervision Loss if Detected on Bypassed Wireless Zone</i>	<input type="checkbox"/> Yes	<input type="checkbox"/> No
[8] <i>Future Use</i>	<input type="checkbox"/> N/A	<input type="checkbox"/> N/A

SECTION [132]: Zone Options

Option	OFF	ON																			
[1]&[2]	<table border="1" style="width: 100%; border-collapse: collapse;"> <thead> <tr> <th colspan="3" style="text-align: center;">Tamper Recognition Options</th> </tr> <tr> <th style="width: 10%;">[1]</th> <th style="width: 10%;">[2]</th> <th></th> </tr> </thead> <tbody> <tr> <td>OFF</td> <td>OFF</td> <td>Disabled (default)</td> </tr> <tr> <td>OFF</td> <td>ON</td> <td>When disarmed: GENERATES TROUBLE ONLY When armed: Follows <i>Zone Alarm Types</i></td> </tr> <tr> <td>ON</td> <td>OFF</td> <td>When disarmed: GENERATES SILENT ALARM When armed: Follows <i>Zone Alarm Types</i></td> </tr> <tr> <td>ON</td> <td>ON</td> <td>When disarmed: GENERATES AUDIBLE ALARM When armed: Follows <i>Zone Alarm Types</i></td> </tr> </tbody> </table>	Tamper Recognition Options			[1]	[2]		OFF	OFF	Disabled (default)	OFF	ON	When disarmed: GENERATES TROUBLE ONLY When armed: Follows <i>Zone Alarm Types</i>	ON	OFF	When disarmed: GENERATES SILENT ALARM When armed: Follows <i>Zone Alarm Types</i>	ON	ON	When disarmed: GENERATES AUDIBLE ALARM When armed: Follows <i>Zone Alarm Types</i>	<input type="checkbox"/> see table <input type="checkbox"/> see table	<input type="checkbox"/> see table <input type="checkbox"/> see table
Tamper Recognition Options																					
[1]	[2]																				
OFF	OFF	Disabled (default)																			
OFF	ON	When disarmed: GENERATES TROUBLE ONLY When armed: Follows <i>Zone Alarm Types</i>																			
ON	OFF	When disarmed: GENERATES SILENT ALARM When armed: Follows <i>Zone Alarm Types</i>																			
ON	ON	When disarmed: GENERATES AUDIBLE ALARM When armed: Follows <i>Zone Alarm Types</i>																			
[3] <i>Generate Tamper if detected on Bypassed Zone</i>	<input type="checkbox"/> Yes	<input type="checkbox"/> No																			
[4] <i>EOL (end-of-line) Resistors</i>	<input type="checkbox"/> No EOL	<input type="checkbox"/> Use EOL Resistors																			
[5] <i>ATZ Zone Doubling (1728 and 1738 only)</i>	<input type="checkbox"/> Disabled	<input type="checkbox"/> Enabled																			
[6] <i>Report Zone Restore</i>	<input type="checkbox"/> On Bell Cut-off	<input type="checkbox"/> On Zone Closure																			
[7]&[8]	<table border="1" style="width: 100%; border-collapse: collapse;"> <thead> <tr> <th colspan="3" style="text-align: center;">Wireless Transmitter Supervision Options</th> </tr> <tr> <th style="width: 10%;">[7]</th> <th style="width: 10%;">[8]</th> <th></th> </tr> </thead> <tbody> <tr> <td>OFF</td> <td>OFF</td> <td>Disabled (default)</td> </tr> <tr> <td>OFF</td> <td>ON</td> <td>When disarmed: GENERATES TROUBLE ONLY When armed: Follows <i>Zone Alarm Types</i></td> </tr> <tr> <td>ON</td> <td>OFF</td> <td>When disarmed: GENERATES SILENT ALARM When armed: Follows <i>Zone Alarm Types</i></td> </tr> <tr> <td>ON</td> <td>ON</td> <td>When disarmed: GENERATES AUDIBLE ALARM When armed: Follows <i>Zone Alarm Types</i></td> </tr> </tbody> </table>	Wireless Transmitter Supervision Options			[7]	[8]		OFF	OFF	Disabled (default)	OFF	ON	When disarmed: GENERATES TROUBLE ONLY When armed: Follows <i>Zone Alarm Types</i>	ON	OFF	When disarmed: GENERATES SILENT ALARM When armed: Follows <i>Zone Alarm Types</i>	ON	ON	When disarmed: GENERATES AUDIBLE ALARM When armed: Follows <i>Zone Alarm Types</i>	<input type="checkbox"/> see table <input type="checkbox"/> see table	<input type="checkbox"/> see table <input type="checkbox"/> see table
Wireless Transmitter Supervision Options																					
[7]	[8]																				
OFF	OFF	Disabled (default)																			
OFF	ON	When disarmed: GENERATES TROUBLE ONLY When armed: Follows <i>Zone Alarm Types</i>																			
ON	OFF	When disarmed: GENERATES SILENT ALARM When armed: Follows <i>Zone Alarm Types</i>																			
ON	ON	When disarmed: GENERATES AUDIBLE ALARM When armed: Follows <i>Zone Alarm Types</i>																			

Bold = Default Setting

SECTION [133]: Partition 1 Options

Option	OFF	ON
[1] <i>Auto-Arm on Time</i>	<input type="checkbox"/> Disabled	<input type="checkbox"/> Enabled
[2] <i>Auto-Arm on No Movement</i>	<input type="checkbox"/> Disabled	<input type="checkbox"/> Enabled
[3] <i>Auto Arming = Regular or Stay</i>	<input type="checkbox"/> Regular Arming	<input type="checkbox"/> Stay Arming
[4] <i>Switch to Stay Arming if no entry delay is opened</i>	<input type="checkbox"/> Disabled	<input type="checkbox"/> Enabled
[5] <i>Stay Arming with Delay Partition 1 (Delay = [070])</i>	<input type="checkbox"/> Disabled	<input type="checkbox"/> Enabled
[6] <i>Future Use</i>	<input type="checkbox"/> N/A	<input type="checkbox"/> N/A
[7] <i>Future Use</i>	<input type="checkbox"/> N/A	<input type="checkbox"/> N/A
[8] <i>Future Use</i>	<input type="checkbox"/> N/A	<input type="checkbox"/> N/A

SECTION [134]: Partition 2 Options

Option	OFF	ON
[1] <i>Auto-Arm on Time</i>	<input type="checkbox"/> Disabled	<input type="checkbox"/> Enabled
[2] <i>Auto-Arm on No Movement</i>	<input type="checkbox"/> Disabled	<input type="checkbox"/> Enabled
[3] <i>Auto Arming = Regular or Stay</i>	<input type="checkbox"/> Regular Arming	<input type="checkbox"/> Stay Arming
[4] <i>Switch to Stay Arming if no entry delay is opened</i>	<input type="checkbox"/> Disabled	<input type="checkbox"/> Enabled
[5] <i>Stay Arming with Delay Partition 2 (Delay = [070])</i>	<input type="checkbox"/> Disabled	<input type="checkbox"/> Enabled
[6] <i>Future Use</i>	<input type="checkbox"/> N/A	<input type="checkbox"/> N/A
[7] <i>Future Use</i>	<input type="checkbox"/> N/A	<input type="checkbox"/> N/A
[8] <i>Future Use</i>	<input type="checkbox"/> N/A	<input type="checkbox"/> N/A

SECTION [135]: Dialer Options

Option	OFF	ON																		
[1]&[2]	<table border="1"> <thead> <tr> <th colspan="3">Telephone Line Monitoring (TLM) Options</th> </tr> <tr> <th>[1]</th> <th>[2]</th> <th></th> </tr> </thead> <tbody> <tr> <td>OFF</td> <td>OFF</td> <td>TLM Disabled (default)</td> </tr> <tr> <td>OFF</td> <td>ON</td> <td>TLM generates a trouble if armed</td> </tr> <tr> <td>ON</td> <td>OFF</td> <td>TLM generates an audible alarm if armed</td> </tr> <tr> <td>ON</td> <td>ON</td> <td>Silent alarms become audible</td> </tr> </tbody> </table>	Telephone Line Monitoring (TLM) Options			[1]	[2]		OFF	OFF	TLM Disabled (default)	OFF	ON	TLM generates a trouble if armed	ON	OFF	TLM generates an audible alarm if armed	ON	ON	Silent alarms become audible	<input type="checkbox"/> see table <input type="checkbox"/> see table
Telephone Line Monitoring (TLM) Options																				
[1]	[2]																			
OFF	OFF	TLM Disabled (default)																		
OFF	ON	TLM generates a trouble if armed																		
ON	OFF	TLM generates an audible alarm if armed																		
ON	ON	Silent alarms become audible																		
[3] <i>Reporting (Dialer)</i>	<input type="checkbox"/> Disabled	<input type="checkbox"/> Enabled																		
[4] <i>Dialing Method</i>	<input type="checkbox"/> Pulse Dialing	<input type="checkbox"/> Tone (DTMF) Dialing																		
[5] <i>Pulse Ratio</i>	<input type="checkbox"/> 1:2	<input type="checkbox"/> 1:1.5																		
[6] <i>If armed, activate bell output on Com. Failure</i>	<input type="checkbox"/> Disabled	<input type="checkbox"/> Enabled																		
[7] <i>Future Use</i>	<input type="checkbox"/> N/A	<input type="checkbox"/> N/A																		
[8] <i>Future Use</i>	<input type="checkbox"/> N/A	<input type="checkbox"/> N/A																		

Bold = Default Setting

SECTION [136]: Dialer Options

Option	OFF	ON
[1] <i>Call Back WinLoad</i>	<input type="checkbox"/> Disabled	<input type="checkbox"/> Enabled
[2] <i>Automatic Event Buffer Transmission</i>	<input type="checkbox"/> Disabled	<input type="checkbox"/> Enabled
[3] <i>Contact I.D. Report Codes</i>	<input type="checkbox"/> Programmable	<input type="checkbox"/> All Codes (automatic)
[4] <i>Alternate Dial</i>	<input type="checkbox"/> Disabled	<input type="checkbox"/> Enabled
[5] <i>If no dial tone is present</i>	<input type="checkbox"/> Continue after 4 sec.	<input type="checkbox"/> Hang-up after 16 sec.
[6]&[7]	<input type="checkbox"/> see table	<input type="checkbox"/> see table
	<input type="checkbox"/> see table	<input type="checkbox"/> see table
[8] <i>Future Use</i>	<input type="checkbox"/> N/A	<input type="checkbox"/> N/A

[6]	[7]	
OFF	OFF	1 call to pager or cellular telephone (default)
OFF	ON	2 calls to pager or cellular telephone
ON	OFF	3 calls to pager or cellular telephone
ON	ON	4 calls to pager or cellular telephone

SECTION [137]: Event Call Direction

Option	OFF	ON
[1] <i>Call Telephone #1 for Arming/Disarming Report Codes</i>	<input type="checkbox"/> Disabled	<input type="checkbox"/> Enabled
[2] <i>Call Telephone #2 for Arming/Disarming Report Codes</i>	<input type="checkbox"/> Disabled	<input type="checkbox"/> Enabled
[3] <i>Call Telephone #1 for Alarm/Restore Report Codes</i>	<input type="checkbox"/> Disabled	<input type="checkbox"/> Enabled
[4] <i>Call Telephone #2 for Alarm/Restore Report Codes</i>	<input type="checkbox"/> Disabled	<input type="checkbox"/> Enabled
[5] <i>Call Telephone #1 for Tamper/Restore Report Codes</i>	<input type="checkbox"/> Disabled	<input type="checkbox"/> Enabled
[6] <i>Call Telephone #2 for Tamper/Restore Report Codes</i>	<input type="checkbox"/> Disabled	<input type="checkbox"/> Enabled
[7] <i>Future Use</i>	<input type="checkbox"/> N/A	<input type="checkbox"/> N/A
[8] <i>Future Use</i>	<input type="checkbox"/> N/A	<input type="checkbox"/> N/A

SECTION [138]: Event Call Direction

Option	OFF	ON
[1] <i>Call Telephone #1 for Trouble/Restore Report Codes</i>	<input type="checkbox"/> Disabled	<input type="checkbox"/> Enabled
[2] <i>Call Telephone #2 for Trouble/Restore Report Codes</i>	<input type="checkbox"/> Disabled	<input type="checkbox"/> Enabled
[3] <i>Call Telephone #1 for Special Report Codes</i>	<input type="checkbox"/> Disabled	<input type="checkbox"/> Enabled
[4] <i>Call Telephone #2 for Special Report Codes</i>	<input type="checkbox"/> Disabled	<input type="checkbox"/> Enabled
[5] <i>Future Use</i>	<input type="checkbox"/> N/A	<input type="checkbox"/> N/A
[6] <i>Future Use</i>	<input type="checkbox"/> N/A	<input type="checkbox"/> N/A
[7] <i>Future Use</i>	<input type="checkbox"/> N/A	<input type="checkbox"/> N/A
[8] <i>Future Use</i>	<input type="checkbox"/> N/A	<input type="checkbox"/> N/A

COMMUNICATION SETTINGS

Section

- [140] ___ / ___ REPORTING FORMATS
TEL1 TEL2 **1** = ADEMCO SLOW (1400HZ, 1900HZ, 10BPS)
 2 = SILENT KNIGHT FAST (1400HZ, 1900HZ, 20BPS)
 3 = SESCOA (2300HZ, 1800HZ, 20BPS)
 4 = ADEMCO EXPRESS (DTMF 4+2)
 5 = ADEMCO CONTACT ID (DEFAULT) ALSO, SEE OPTION [3] IN SECTION [136]
 6 = PAGER FORMAT

 **If Hexadecimals (0 to FF) are used to program the report codes, verify that the pager also supports Hexadecimals. If the pager does not support Hexadecimals, use only the digits 0 to 9.**

- [141] ___/___/___/___ PANEL IDENTIFIER (WINLOAD SOFTWARE)
[142] ___/___/___/___ PC PASSWORD (WINLOAD SOFTWARE)
- [143] ___/___/___/___ PARTITION ACCOUNT NUMBER 1 (For less than 4 digits, use the [FORCE] key to enter blanks.)
[144] ___/___/___/___ PARTITION ACCOUNT NUMBER 2 (For less than 4 digits, use the [FORCE] key to enter blanks.)
- [150] _____
PC TELEPHONE NUMBER FOR WINLOAD SOFTWARE (32-digits, if less than 32 press [ENTER] to accept)
- [151] _____
CENTRAL STATION TELEPHONE OR PAGER NUMBER 1 (32-digits, if less than 32 press [ENTER] to accept)
- [152] _____
CENTRAL STATION TELEPHONE OR PAGER NUMBER 2 (32-digits, if less than 32 press [ENTER] to accept)
- [153] _____
BACK UP TELEPHONE NUMBER (32-digits, if less than 32 press [ENTER] to accept)

Special Keys for Telephone Numbers

[STAY] = *	[MEM] = Switch from pulse to tone dialing or vice versa	[FORCE] = Delete current digit
[BYP] = #	[TBL] or [TRBL] = 4-second pause	[PG] or [FNC1] = Inserts Blank Space

REPORT CODES

Ademco Slow, Silent Knight, SESCOA, Ademco Express and Pager Formats: Enter the desired 1- or 2-digit hexa-value (0-F or 00-FF). **Ademco “Programmable” Format:** Enter the desired 2-digit hexa values from the “Ademco Report Code List - Programmable” (see Appendix A on page30). Also Note that entering FF will set the report code to the default Ademco Report Code. **Ademco “All Codes” Format:** The control panel automatically generates report codes from the “Ademco Report Code List - All Codes” (see Appendix B on page31).

ARMING REPORT CODES

[160] ___/___ Access Code 01
___/___ Access Code 02
___/___ Access Code 03
___/___ Access Code 04

[165] ___/___ Access Code 21
___/___ Access Code 22
___/___ Access Code 23
___/___ Access Code 24

[170] ___/___ Access Code 41
___/___ Access Code 42
___/___ Access Code 43
___/___ Access Code 44

[161] ___/___ Access Code 05
___/___ Access Code 06
___/___ Access Code 07
___/___ Access Code 08

[166] ___/___ Access Code 25
___/___ Access Code 26
___/___ Access Code 27
___/___ Access Code 28

[171] ___/___ Access Code 45
___/___ Access Code 46
___/___ Access Code 47
___/___ Access Code 48

[162] ___/___ Access Code 09
___/___ Access Code 10
___/___ Access Code 11
___/___ Access Code 12

[167] ___/___ Access Code 29
___/___ Access Code 30
___/___ Access Code 31
___/___ Access Code 32

[163] ___/___ Access Code 13
___/___ Access Code 14
___/___ Access Code 15
___/___ Access Code 16

[168] ___/___ Access Code 33
___/___ Access Code 34
___/___ Access Code 35
___/___ Access Code 36

SPECIAL ARMING CODES

[172] ___/___ Auto-Arming
___/___ Late to Close
___/___ No Movement
___/___ Partial Arming

[164] ___/___ Access Code 17
___/___ Access Code 18
___/___ Access Code 19
___/___ Access Code 20

[169] ___/___ Access Code 37
___/___ Access Code 38
___/___ Access Code 39
___/___ Access Code 40

[173] ___/___ Quick Arming
___/___ Arming via PC
___/___ Keypad Arming
___/___ N/A

DISARMING REPORT CODES

[174] ___/___ Access Code 01
___/___ Access Code 02
___/___ Access Code 03
___/___ Access Code 04

[179] ___/___ Access Code 21
___/___ Access Code 22
___/___ Access Code 23
___/___ Access Code 24

[184] ___/___ Access Code 41
___/___ Access Code 42
___/___ Access Code 43
___/___ Access Code 44

[175] ___/___ Access Code 05
___/___ Access Code 06
___/___ Access Code 07
___/___ Access Code 08

[180] ___/___ Access Code 25
___/___ Access Code 26
___/___ Access Code 27
___/___ Access Code 28

[185] ___/___ Access Code 45
___/___ Access Code 46
___/___ Access Code 47
___/___ Access Code 48

[176] ___/___ Access Code 09
___/___ Access Code 10
___/___ Access Code 11
___/___ Access Code 12

[181] ___/___ Access Code 29
___/___ Access Code 30
___/___ Access Code 31
___/___ Access Code 32

[177] ___/___ Access Code 13
___/___ Access Code 14
___/___ Access Code 15
___/___ Access Code 16

[182] ___/___ Access Code 33
___/___ Access Code 34
___/___ Access Code 35
___/___ Access Code 36

SPECIAL DISARMING CODES

[186] ___/___ Cancel Auto-Arm
___/___ Disarming via PC
___/___ Keypad Disarm
___/___ N/A

[178] ___/___ Access Code 17
___/___ Access Code 18
___/___ Access Code 19
___/___ Access Code 20

[183] ___/___ Access Code 37
___/___ Access Code 38
___/___ Access Code 39
___/___ Access Code 40

ALARM REPORT CODES

ALARM	RESTORE	SPECIAL
[187] ___/___ Zone 01 ___/___ Zone 02 ___/___ Zone 03 ___/___ Zone 04	[191] ___/___ Zone 01 ___/___ Zone 02 ___/___ Zone 03 ___/___ Zone 04	[195] ___/___ Emergency Panic ___/___ Auxiliary Panic ___/___ Fire Panic ___/___ Recent Closing
[188] ___/___ Zone 05 ___/___ Zone 06 ___/___ Zone 07 ___/___ Zone 08	[192] ___/___ Zone 05 ___/___ Zone 06 ___/___ Zone 07 ___/___ Zone 08	[196] ___/___ Zone Shutdown ___/___ Duress ___/___ Keypad Lockout ___/___ N/A
[189] ___/___ Zone 09 ___/___ Zone 10 ___/___ Zone 11 ___/___ Zone 12	[193] ___/___ Zone 09 ___/___ Zone 10 ___/___ Zone 11 ___/___ Zone 12	
[190] ___/___ Zone 13 ___/___ Zone 14 ___/___ Zone 15 ___/___ Zone 16	[194] ___/___ Zone 13 ___/___ Zone 14 ___/___ Zone 15 ___/___ Zone 16	

TAMPER REPORT CODES

TROUBLE	RESTORE	SPECIAL
[197] ___/___ Zone 01 ___/___ Zone 02 ___/___ Zone 03 ___/___ Zone 04	[200] ___/___ Zone 13 ___/___ Zone 14 ___/___ Zone 15 ___/___ Zone 16	[203] ___/___ Zone 09 ___/___ Zone 10 ___/___ Zone 11 ___/___ Zone 12
[198] ___/___ Zone 05 ___/___ Zone 06 ___/___ Zone 07 ___/___ Zone 08	[201] ___/___ Zone 01 ___/___ Zone 02 ___/___ Zone 03 ___/___ Zone 04	[204] ___/___ Zone 13 ___/___ Zone 14 ___/___ Zone 15 ___/___ Zone 16
[199] ___/___ Zone 09 ___/___ Zone 10 ___/___ Zone 11 ___/___ Zone 12	[202] ___/___ Zone 05 ___/___ Zone 06 ___/___ Zone 07 ___/___ Zone 08	

SYSTEM TROUBLE REPORT CODES

SYSTEM TROUBLE	RESTORE	SPECIAL
[205] ___/___ N/A ___/___ AC Failure ___/___ Battery Failure ___/___ Auxiliary Supply	[208] ___/___ TLM ___/___ AC Failure ___/___ Battery Failure ___/___ Auxiliary Supply	[211] ___/___ Cold Start (Shutdown) ___/___ Test Report ___/___ N/A ___/___ PC Exit
[206] ___/___ Bell Output Overload ___/___ Bell Output Disconnect ___/___ Timer Loss ___/___ Fire Loop Trouble	[209] ___/___ Bell Output Overload ___/___ Bell Output Disconnect ___/___ Timer Loss ___/___ Fire Loop Trouble	[212] ___/___ Installer In ___/___ Installer Out ___/___ N/A ___/___ N/A
[207] ___/___ Wireless Low Battery ___/___ Module Fault ___/___ Printer Fault ___/___ Fail to Communicate	[210] ___/___ Wireless Low Battery ___/___ Module Fault ___/___ Printer Fault ___/___ Fail to Communicate	[213] ___/___ TX Supervision Loss ___/___ TX Supervision Restore ___/___ N/A ___/___ N/A

SYSTEM SETTINGS

Section #	Description
[280] __/__:__/_	SYSTEM REAL TIME CLOCK (HH:MM)
[281] __/__/__/_/___/___	INSTALLER CODE, DEFAULT: 000000
[282] __/__/___	INSTALLER CODE LOCK, DEFAULT: 000 (147 TO LOCK, 000 TO UNLOCK)
[301] __/__/__/_/___/___	SYSTEM MASTER CODE, DEFAULT: 123456

USER CODE OPTIONS

System Master Code arms or disarm partitions using any arming method and can create, modify or delete any *User Access Code*. Only the System Master Code can modify or delete User Access Codes assigned to both partitions.

Master Code 1 is permanently assigned to partition 1 and can be used to create, modify or delete *User Access Codes* that are assigned to partition 1.

Master Code 2 is permanently assigned to partition 2 (except when partitioning is disabled, *Master Code 2* will be assigned to partition 1) and can be used to create, modify or delete *User Access Codes* that are assigned to the same partition.

Default for all user codes is options [1], [3] and [4] ON.
 ON = Option Enabled
 OFF = Option Disabled

[1] ON = Partition 1 Access	[5] ON = Force Arming
[2] ON = Partition 2 Access	[6] ON = Arm Only
[3] ON = Bypass Programming	[7] ON = PGM Activation Only
[4] ON = Stay Arming	[8] ON = Future Use

Section #	User Code Options (ON/OFF)	Section	User Code Options (ON/OFF)
[302] Master Code 1	1 2 3 4 5 6 7 8	[325] User Code 025	1 2 3 4 5 6 7 8
[303] Master Code 2	1 2 3 4 5 6 7 8	[326] User Code 026	1 2 3 4 5 6 7 8
[304] User Code 004	1 2 3 4 5 6 7 8	[327] User Code 027	1 2 3 4 5 6 7 8
[305] User Code 005	1 2 3 4 5 6 7 8	[328] User Code 028	1 2 3 4 5 6 7 8
[306] User Code 006	1 2 3 4 5 6 7 8	[329] User Code 029	1 2 3 4 5 6 7 8
[307] User Code 007	1 2 3 4 5 6 7 8	[330] User Code 030	1 2 3 4 5 6 7 8
[308] User Code 008	1 2 3 4 5 6 7 8	[331] User Code 031	1 2 3 4 5 6 7 8
[309] User Code 009	1 2 3 4 5 6 7 8	[332] User Code 032	1 2 3 4 5 6 7 8
[310] User Code 010	1 2 3 4 5 6 7 8	[333] User Code 033	1 2 3 4 5 6 7 8
[311] User Code 011	1 2 3 4 5 6 7 8	[334] User Code 034	1 2 3 4 5 6 7 8
[312] User Code 012	1 2 3 4 5 6 7 8	[335] User Code 035	1 2 3 4 5 6 7 8
[313] User Code 013	1 2 3 4 5 6 7 8	[336] User Code 036	1 2 3 4 5 6 7 8
[314] User Code 014	1 2 3 4 5 6 7 8	[337] User Code 037	1 2 3 4 5 6 7 8
[315] User Code 015	1 2 3 4 5 6 7 8	[338] User Code 038	1 2 3 4 5 6 7 8
[316] User Code 016	1 2 3 4 5 6 7 8	[339] User Code 039	1 2 3 4 5 6 7 8
[317] User Code 017	1 2 3 4 5 6 7 8	[340] User Code 040	1 2 3 4 5 6 7 8
[318] User Code 018	1 2 3 4 5 6 7 8	[341] User Code 041	1 2 3 4 5 6 7 8
[319] User Code 019	1 2 3 4 5 6 7 8	[342] User Code 042	1 2 3 4 5 6 7 8
[320] User Code 020	1 2 3 4 5 6 7 8	[343] User Code 043	1 2 3 4 5 6 7 8
[321] User Code 021	1 2 3 4 5 6 7 8	[344] User Code 044	1 2 3 4 5 6 7 8
[322] User Code 022	1 2 3 4 5 6 7 8	[345] User Code 045	1 2 3 4 5 6 7 8
[323] User Code 023	1 2 3 4 5 6 7 8	[346] User Code 046	1 2 3 4 5 6 7 8
[324] User Code 024	1 2 3 4 5 6 7 8	[347] User Code 047	1 2 3 4 5 6 7 8
		[348] User Code 048	1 2 3 4 5 6 7 8

REPROGRAM ALL MODULES

[750] After removing an expansion module from the communication bus, the control panel keeps the module's programmed sections in memory. Therefore, if you add or replace a module you can re-program the module with the settings saved in the control panel. To do so, enter section **[750]** and press **[ENTER]**. The keypads will beep twice every second until the procedure is completed.

PARADOX MEMORY KEY (PMC-3)

[900] DOWNLOAD FROM PARADOX MEMORY KEY TO DESTINATION CONTROL PANEL.

[902] COPY TO MEMORY KEY FROM SOURCE CONTROL PANEL.

Download to DESTINATION Control Panel

- 1) Remove AC and battery power from the control panel.
- 2) Insert the Memory Key onto the serial connector labelled KEY on the Spectra control panel to which you wish to download the contents of the memory key to.
- 3) Re-apply AC and battery power.
- 4) Enter installer programming mode, enter section **[900]**, then press **[ENTER]** to acknowledge.
- 5) When the keypad emits a "confirmation beep", remove the *Memory Key*.
- 6) Enter section **[750]** to reprogram the modules with the information downloaded from the Paradox Memory Key.

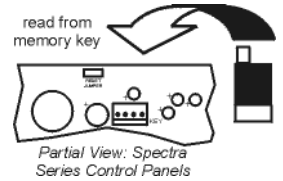

Copy to Memory Key from SOURCE Control Panel

- 1) Remove AC and battery power from the control panel.
- 2) Insert Memory Key onto the serial connector labelled KEY on the Spectra control panel that you want to copy. Make sure the write protect jumper of the Memory Key is on.
- 3) Re-apply AC and battery power.
- 4) Enter installer programming mode, enter section **[902]**, then press **[ENTER]** to acknowledge.
- 5) When the keypad emits a Confirmation Beep, remove the Memory Key. Remove the *Memory Key's* jumper if you do not wish to accidentally overwrite its contents.

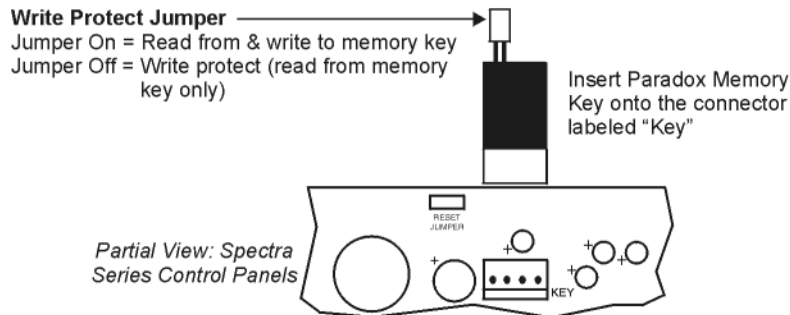
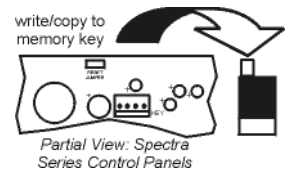

4-OUTPUT BUS MODULE V1.0

Due to the APR3-PGM4's Auto-recognition feature, it can be used with either the Spectra (V2.0 or higher), Digiplex or DigiplexNE control panel. When connected to the bus, the APR3-PGM4 automatically detects which control panel it is connected to and adjusts its internal communication parameters to function accordingly. Only one APR3-PGM4 can be connected to each Spectra control panel.

 Modules with the APR- prefix are compatible with Spectra (versions 2.0 and higher) and Digiplex. Modules with the APR3- prefix are compatible with Spectra (versions 2.0 and higher), Digiplex and DigiplexNE.

Bold = Default Setting

SECTION [500]: GENERAL OPTIONS

Option	OFF	ON
[1] <i>PGM1 Time Base Selection</i>	<input type="checkbox"/> Seconds	<input type="checkbox"/> Minutes
[2] <i>PGM2 Time Base Selection</i>	<input type="checkbox"/> Seconds	<input type="checkbox"/> Minutes
[3] <i>PGM3 Time Base Selection</i>	<input type="checkbox"/> Seconds	<input type="checkbox"/> Minutes
[4] <i>PGM4 Time Base Selection</i>	<input type="checkbox"/> Seconds	<input type="checkbox"/> Minutes
[5] <i>Future Use</i>	<input type="checkbox"/> N/A	<input type="checkbox"/> N/A
[6] <i>Future Use</i>	<input type="checkbox"/> N/A	<input type="checkbox"/> N/A
[7] <i>Future Use</i>	<input type="checkbox"/> N/A	<input type="checkbox"/> N/A
[8] <i>Future Use</i>	<input type="checkbox"/> N/A	<input type="checkbox"/> N/A

PGM PROGRAMMING

Each PGM Deactivation event can be used as another activation event if their respective PGM timer (see sections [501] to [504]) is programmed with a value other than 000. The APR3-PGM4 uses the same PGM events as the Spectra control panel, please refer to "Programmable Outputs" on page 7.

Section #	Decimal Value (000-255)	Description	Default Value
[501] ___/___/___	(000 = follow deactivation event)	PGM1 TIMER	5 sec.
[502] ___/___/___	(000 = follow deactivation event)	PGM2 TIMER	5 sec.
[503] ___/___/___	(000 = follow deactivation event)	PGM3 TIMER	5 sec.
[504] ___/___/___	(000 = follow deactivation event)	PGM4 TIMER	5 sec.

Section #	Event Group #	Sub-Group #	Partition #
[505] PGM1 Activation Event	___/___	___/___	___/___
[506] PGM1 Deactivation Event	___/___	___/___	___/___
[507] PGM2 Activation Event	___/___	___/___	___/___
[508] PGM2 Deactivation Event	___/___	___/___	___/___
[509] PGM3 Activation Event	___/___	___/___	___/___
[510] PGM3 Deactivation Event	___/___	___/___	___/___
[511] PGM4 Activation Event	___/___	___/___	___/___
[512] PGM4 Deactivation Event	___/___	___/___	___/___

PRINTER BUS MODULE V1.1

Due to the APR3-PRT1's Auto-recognition feature, it can be used with either the Spectra (V2.0 or higher), Digiplex or DigiplexNE control panel. When connected to the bus, the APR3-PRT1 automatically detects which control panel it is connected to and adjusts its internal communication parameters to function accordingly. Only one APR3-PRT1 can be connected to each Spectra control panel.

 Modules with the APR- prefix are compatible with Spectra (versions 2.0 and higher) and Digiplex. Modules with the APR3- prefix are compatible with Spectra (versions 2.0 and higher), Digiplex and DigiplexNE.

Bold = Default Setting

SECTION [550]: GENERAL OPTIONS

Option	OFF	ON
[1] <i>Assigned to Partition 1</i>	<input type="checkbox"/> Disabled	<input type="checkbox"/> Enabled
[2] <i>Assigned to Partition 2</i>	<input type="checkbox"/> Disabled	<input type="checkbox"/> Enabled
[3] <i>PGM Normal State</i>	<input type="checkbox"/> Normally Open (N.O.)	<input type="checkbox"/> Normally Closed (N.C.)
[4] <i>Print Arming and Disarming Events</i>	<input type="checkbox"/> Disabled	<input type="checkbox"/> Automatically
[5] <i>Print Alarm and Alarm Restore Events</i>	<input type="checkbox"/> Disabled	<input type="checkbox"/> Automatically
[6] <i>Print Tamper and Tamper Restore Events</i>	<input type="checkbox"/> Disabled	<input type="checkbox"/> Automatically
[7] <i>Print Trouble and Trouble Restore Events</i>	<input type="checkbox"/> Disabled	<input type="checkbox"/> Automatically
[8] <i>Print Special Events</i>	<input type="checkbox"/> Disabled	<input type="checkbox"/> Automatically

SECTION [551]: AUTOMATIC ZONE STATUS PRINTING

Option	OFF	ON
[1] <i>Print Status of Zone 1</i>	<input type="checkbox"/> Disabled	<input type="checkbox"/> Automatically
[2] <i>Print Status of Zone 2</i>	<input type="checkbox"/> Disabled	<input type="checkbox"/> Automatically
[3] <i>Print Status of Zone 3</i>	<input type="checkbox"/> Disabled	<input type="checkbox"/> Automatically
[4] <i>Print Status of Zone 4</i>	<input type="checkbox"/> Disabled	<input type="checkbox"/> Automatically
[5] <i>Print Status of Zone 5</i>	<input type="checkbox"/> Disabled	<input type="checkbox"/> Automatically
[6] <i>Print Status of Zone 6</i>	<input type="checkbox"/> Disabled	<input type="checkbox"/> Automatically
[7] <i>Print Status of Zone 7</i>	<input type="checkbox"/> Disabled	<input type="checkbox"/> Automatically
[8] <i>Print Status of Zone 8</i>	<input type="checkbox"/> Disabled	<input type="checkbox"/> Automatically

SECTION [552]: AUTOMATIC ZONE STATUS PRINTING

Option	OFF	ON
[1] <i>Print Status of Zone 9</i>	<input type="checkbox"/> Disabled	<input type="checkbox"/> Automatically
[2] <i>Print Status of Zone 10</i>	<input type="checkbox"/> Disabled	<input type="checkbox"/> Automatically
[3] <i>Print Status of Zone 11</i>	<input type="checkbox"/> Disabled	<input type="checkbox"/> Automatically
[4] <i>Print Status of Zone 12</i>	<input type="checkbox"/> Disabled	<input type="checkbox"/> Automatically
[5] <i>Print Status of Zone 13</i>	<input type="checkbox"/> Disabled	<input type="checkbox"/> Automatically
[6] <i>Print Status of Zone 14</i>	<input type="checkbox"/> Disabled	<input type="checkbox"/> Automatically
[7] <i>Print Status of Zone 15</i>	<input type="checkbox"/> Disabled	<input type="checkbox"/> Automatically
[8] <i>Print Status of Zone 16</i>	<input type="checkbox"/> Disabled	<input type="checkbox"/> Automatically

Bold = Default Setting

SECTION [553]: SERIAL AND PARALLEL PORT SETUP OPTIONS

Option		OFF	ON																							
[1]	<i>Serial Port</i>	<input type="checkbox"/> Disabled	<input type="checkbox"/> Enabled																							
[2]&[3]	<table border="1" style="width: 100%; border-collapse: collapse; text-align: center;"> <thead> <tr> <th colspan="4">Baud Rate Settings</th> </tr> <tr> <th>[2]</th> <th>[3]</th> <th>APR-PRT1</th> <th>APR3-PRT1</th> </tr> </thead> <tbody> <tr> <td>OFF</td> <td>OFF</td> <td>1200 baud (default)</td> <td>2400 baud (default)</td> </tr> <tr> <td>ON</td> <td>OFF</td> <td>2400 baud</td> <td>9600 baud</td> </tr> <tr> <td>OFF</td> <td>ON</td> <td>9600 baud</td> <td>19200 baud</td> </tr> <tr> <td>ON</td> <td>ON</td> <td>19200 baud</td> <td>57600 baud</td> </tr> </tbody> </table>	Baud Rate Settings				[2]	[3]	APR-PRT1	APR3-PRT1	OFF	OFF	1200 baud (default)	2400 baud (default)	ON	OFF	2400 baud	9600 baud	OFF	ON	9600 baud	19200 baud	ON	ON	19200 baud	57600 baud	<input type="checkbox"/> see table <input type="checkbox"/> see table
Baud Rate Settings																										
[2]	[3]	APR-PRT1	APR3-PRT1																							
OFF	OFF	1200 baud (default)	2400 baud (default)																							
ON	OFF	2400 baud	9600 baud																							
OFF	ON	9600 baud	19200 baud																							
ON	ON	19200 baud	57600 baud																							
[4]	<i>Parallel Port</i>	<input type="checkbox"/> Disabled	<input type="checkbox"/> Enabled																							
[5]	<i>Off-line Status Ignored (parallel port only)</i>	<input type="checkbox"/> Disabled	<input type="checkbox"/> Enabled																							
[6]	<i>Paper Empty Status Ignored (parallel port only)</i>	<input type="checkbox"/> Disabled	<input type="checkbox"/> Enabled																							
[7]	<i>Printer Fault Status Ignored (parallel port only)</i>	<input type="checkbox"/> Disabled	<input type="checkbox"/> Enabled																							
[8]	<i>Printer Busy Status Ignored (parallel port only)</i>	<input type="checkbox"/> Disabled	<input type="checkbox"/> Enabled																							

PGM PROGRAMMING

The PGM Deactivation event can be used as another activation event if the PGM Timer (section [554]) is programmed with a value other than 000. The PRT1 module uses the same PGM events as the Spectra control panel, please refer to "Programmable Outputs" on page 7

Section #	Decimal Value (000-255)	Description	Default Value
[554]	___/___/___ seconds (000 = follow deactivation event)	PGM1 TIMER	5 sec.

Section #	Event Group #	Sub-Group #	Partition #
[555] PGM1 Activation Event	___/___	___/___	___/___
[556] PGM1 Deactivation Event	___/___	___/___	___/___

CLOCK PROGRAMMING

For example, to enter the date March 26, 2000 you would enter 20 (century), 00 (year), 03 (month), and 26 (day).

Section #	Value
[557]	Year ___/___/___/___ Month ___/___ Day ___/___



VOICE-ASSISTED ARM/DISARM BUS MODULE V1.0

Due to InTouch's Auto-recognition feature, it can be used with either the Spectra (V2.0 or higher), Digiplex or DigiplexNE control panel. When connected to the bus, InTouch automatically detects which control panel it is connected to and adjusts its internal communication parameters to function accordingly. Only one InTouch can be connected to each Spectra control panel.

APR3-ADM2 can also be programmed using the WinLoad Software. Refer to the *WinLoad Online Help* for more information.

 Modules with the APR- prefix are compatible with Spectra (versions 2.0 and higher) and Digiplex. Modules with the APR3- prefix are compatible with Spectra (versions 2.0 and higher), Digiplex and DigiplexNE.

Section #	Decimal Value (000-255)	Description	Default Value
[575] ___/___/___	rings (000 = disabled)	NUMBER OF RINGS	<i>8 rings</i>
[576] ___/___/___	seconds (010-255, 000 = disabled)	ANSWERING MACHINE OVERRIDE	<i>000</i>
[577] ___/___/___	seconds/minutes (000 = disabled)	PGM TIMER	<i>005</i>

Bold = Default Setting

SECTION [578]: GENERAL OPTIONS

Option	OFF	ON
[1] <i>Stand-alone Code Length</i>	<input type="checkbox"/> 6-digits	<input type="checkbox"/> 4-digits
[2] <i>Partitioned System</i>	<input type="checkbox"/> Disabled	<input type="checkbox"/> Enabled
[3] <i>PGM Output</i>	<input type="checkbox"/> Disabled	<input type="checkbox"/> Enabled
[4] <i>PGM Time in</i>	<input type="checkbox"/> Seconds	<input type="checkbox"/> Minutes
[5] <i>Future Use</i>	<input type="checkbox"/> N/A	<input type="checkbox"/> N/A
[6] <i>Future Use</i>	<input type="checkbox"/> N/A	<input type="checkbox"/> N/A
[7] <i>Future Use</i>	<input type="checkbox"/> N/A	<input type="checkbox"/> N/A
[8] <i>Future Use</i>	<input type="checkbox"/> N/A	<input type="checkbox"/> N/A

WIRELESS BUS MODULES



Only one SPC-319 (Liberator) or OMN-RCV3 (Omnia) can be connected to each Spectra control panel.

ZONE ASSIGNMENT

The serial number can be located on the inside of the transmitter or you can use the *Serial Number Display* feature (see page 25). **Also, refer to “Zone Recognition Table” on page 4.**

- Section # Serial #
- [601] ___/___/___/___/___ = EXPANSION INPUT 1
- [602] ___/___/___/___/___ = EXPANSION INPUT 2
- [603] ___/___/___/___/___ = EXPANSION INPUT 3
- [604] ___/___/___/___/___ = EXPANSION INPUT 4
- [605] ___/___/___/___/___ = EXPANSION INPUT 5
- [606] ___/___/___/___/___ = EXPANSION INPUT 6
- [607] ___/___/___/___/___ = EXPANSION INPUT 7
- [608] ___/___/___/___/___ = EXPANSION INPUT 8



Bold = Default Setting

SECTION [610]: GENERAL OPTIONS

Option	OFF	ON
[1] <i>Wireless Transmitter Supervision</i>	<input type="checkbox"/> Disabled	<input type="checkbox"/> Enabled
[2] <i>Supervision Timer Setting (must be same as the transmitter’s jumper setting)</i>	<input type="checkbox"/> Low = Every 12 hours	<input type="checkbox"/> High = Every 12 minutes
[3] <i>PGM1 on SPC-319 follows Global PGM programmed in sections [124] & [125]</i>	<input type="checkbox"/> Disabled	<input type="checkbox"/> Enabled
[4] <i>PGM2 on SPC-319 follows Global PGM programmed in sections [124] & [125]</i>	<input type="checkbox"/> Disabled	<input type="checkbox"/> Enabled
[5] to [8] <i>Future Use</i>	<input type="checkbox"/> N/A	<input type="checkbox"/> N/A



Bold = Default Setting

SECTION [610]: GENERAL OPTIONS

Option	OFF	ON
[1] <i>Wireless Transmitter Check-in Supervision</i>	<input type="checkbox"/> Disabled	<input type="checkbox"/> Enabled
[2] <i>Check-in Supervision Base Time Setting (must be same as the transmitter’s jumper setting)</i>	<input type="checkbox"/> Hours	<input type="checkbox"/> Minutes
[3] & [4] <i>Future Use</i>	<input type="checkbox"/> N/A	<input type="checkbox"/> N/A
[5] <i>Check-in Supervision Time Value (must be same as the transmitter’s jumper setting)</i>	<input type="checkbox"/> 12	<input type="checkbox"/> 6
[6] <i>PGM1 Deactivation</i>	<input type="checkbox"/> 2 second Timer	<input type="checkbox"/> Manually
[7] <i>PGM2 Deactivation</i>	<input type="checkbox"/> 2 second Timer	<input type="checkbox"/> Manually
[8] <i>Future Use</i>	<input type="checkbox"/> N/A	<input type="checkbox"/> N/A

Section #	Decimal Value (000-255)	Description	Default Value
[615]	___/___/___ (001-008 = expansion inputs 1-8)	ON-BOARD TAMPER ZONE ASSIGN.	000

PGM PROGRAMMING (LIBERATOR ONLY)

Each PGM Deactivation event can be used as another activation event if their respective PGM Timer (see sections [616] to [617]) is programmed with a value other than 000. The system will ignore a PGM if it has been programmed to follow the Global PGM (options [3] and [4] in section [610]). Only PGM events from the table below can be used.

 **Only the Liberator's PGMs can be programmed using the PGM events from the table below.**

Section #	Decimal Value (000-255)	Description	Default Value
[616]	___/___/___ seconds (000=follow deactivation)	PGM1 TIMER (SPC-319)	5 sec.
[617]	___/___/___ seconds (000=follow deactivation)	PGM2 TIMER (SPC-319)	5 sec.

Section #	Event Group	Sub-Group	Partition
[620]	PGM1 Activation Event	___/___	___/___
[621]	PGM1 Deactivation Event	___/___	___/___
[622]	PGM2 Activation Event	___/___	___/___
[623]	PGM2 Deactivation Event	___/___	___/___

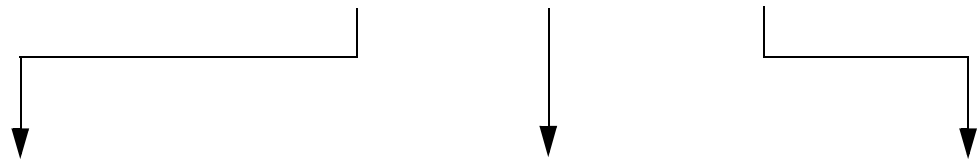

Event Group #	Sub-Group #	Partition #
40 = Wireless Zone Opened 41 = Wireless Zone Closed 42 = Wireless Tamper Opened 43 = Wireless Tamper Closed 44 = Wireless Zone - Low Battery 45 = Wireless Zone -Battery Restore 46 = Wireless Zone - Supervision Failure 47 = Wireless Zone - Supervision Restore	01 = Expansion Input 1 - Section [601] 02 = Expansion Input 2 - Section [602] 03 = Expansion Input 3 - Section [603] 04 = Expansion Input 4 - Section [604] 05 = Expansion Input 5 - Section [605] 06 = Expansion Input 6 - Section [606] 07 = Expansion Input 7 - Section [607] 08 = Expansion Input 8 - Section [608] 99 = Any transmitter	Not used; enter 00
48 = Remote Control Button Pressed	01 = Remote Control #1 - Section [721] 02 = Remote Control #2 - Section [722] 03 = Remote Control #3 - Section [723] 04 = Remote Control #4 - Section [724] 05 = Remote Control #5 - Section [725] 06 = Remote Control #6 - Section [726] 07 = Remote Control #7 - Section [727] 08 = Remote Control #8 - Section [728] 99 = Any remote control	01 = Button A 02 = Button B 03 = Button C 04 = Button D 05 = Button A & B 06 = Button C & D 07 = Button A & C 08 = Button B & D
49 = On-board tamper (receiver)	01 = Tamper Open 02 = Tamper Closed 99 = Tamper Opened or Closed	Not used; enter 00

PGM ACTIVATION/DEACTIVATION (OMNIA ONLY)

PGM1 is always enabled and is activated through the Omnia Remote Control (OMN-RCT1). Remote control button C controls PGM1. A second 5A PGM relay output (PGM2) is available as an option. Remote control button D controls PGM2 (optional). Press the appropriate button to activate the PGM that it controls. Section [610] options [6] and [7] determine how the respective PGM will deactivate. If the option is OFF, the activated PGM will automatically deactivate after 2 seconds. If the option is ON, each activated PGM can be deactivated only by pressing the appropriate button on an Omnia Remote Control that controls a PGM. For a diagram of the Omnia Remote Control, refer to "Button Options" on page 25.

SERIAL NUMBER DISPLAY

Section #	Description
[630]	Press the tamper switch of the Liberator or Omnia Wireless Transmitter, or press any two buttons on the desired remote control (Liberator only). The keypad will emit a confirmation beep. On LED keypads, press the [ENTER] key to view the digits one at a time. On LCD keypads, the first 3 digits of the serial number will appear. Press the [ENTER] key 3 times to view the next 3 digits. Continue activating the desired transmitters or press [CLEAR] to exit.

SIGNAL STRENGTH DISPLAY

Section #	Description
	After entering the desired section, activate the Liberator or Omnia transmitter by opening/closing the zone or by pressing the tamper switch. Always ignore the first reading as it won't be accurate. An average reading of 3 and up is acceptable.

[631]	Display Signal Strength of Expansion Input 1 - Section [601]
[632]	Display Signal Strength of Expansion Input 2 - Section [602]
[633]	Display Signal Strength of Expansion Input 3 - Section [603]
[634]	Display Signal Strength of Expansion Input 4 - Section [604]
[635]	Display Signal Strength of Expansion Input 5 - Section [605]
[636]	Display Signal Strength of Expansion Input 6 - Section [606]
[637]	Display Signal Strength of Expansion Input 7 - Section [607]
[638]	Display Signal Strength of Expansion Input 8 - Section [608]

REMOTE CONTROL USER ASSIGNMENT

Section #	Decimal Value	Description	Default Value
[701]	___/___/___ (001-048 = user #)	remote control #1 - section [721]/[731]*	000
[702]	___/___/___ (001-048 = user #)	remote control #2 - section [722]/[732]*	000
[703]	___/___/___ (001-048 = user #)	remote control #3 - section [723]/[733]*	000
[704]	___/___/___ (001-048 = user #)	remote control #4 - section [724]/[734]*	000
[705]	___/___/___ (001-048 = user #)	remote control #5 - section [725]/[735]*	000
[706]	___/___/___ (001-048 = user #)	remote control #6 - section [726]/[736]*	000
[707]	___/___/___ (001-048 = user #)	remote control #7 - section [727]/[737]*	000
[708]	___/___/___ (001-048 = user #)	remote control #8 - section [728]/[738]*	000

* refer to "Remote Control Assignment" on page 26.

BUTTON OPTIONS

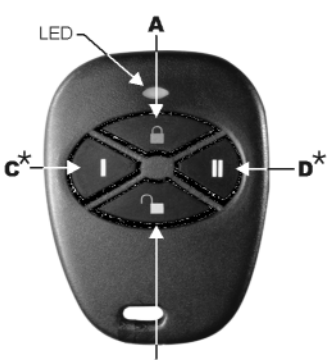
<p>* Note: When using the Omnia remote control (OMN-RCT1), regardless of what is programmed for the button, pressing button C will activate PGM1 while pressing button D will activate PGM2.</p>	<div style="text-align: center;"> <p>Four-button Remote Control</p>  <p>Liberator = (LIB-349) 900MHz Omnia = (OMN-RCT1) 433MHz*</p> </div>
<h3 style="margin: 0;">Button Options Table</h3> <p>Empty Slot [FORCE] - Button disabled</p> <ul style="list-style-type: none"> 1 - Regular Arming 2 - Stay Arming 3 - Instant Arming 4 - Force Arming 5 - Disarm 6 - Disarm when no alarm 7 - Regular Arm and Disarm 8 - Panic 1 9 - Panic 2 A - Panic 3 B - PGM Activation (Event Group #7, see PGM Programming) C - PGM Activation (Event Group #8, see PGM Programming) D - PGM Activation (Event Group #9, see PGM Programming) 	

Section # Hexa Value: Each digit is a value from 1 to D (see Button Options Table)

- [711] / / / / / / / remote control #1
 A B C D A+B C+D A+C B+D
- [712] / / / / / / / remote control #2
 A B C D A+B C+D A+C B+D
- [713] / / / / / / / remote control #3
 A B C D A+B C+D A+C B+D
- [714] / / / / / / / remote control #4
 A B C D A+B C+D A+C B+D
- [715] / / / / / / / remote control #5
 A B C D A+B C+D A+C B+D
- [716] / / / / / / / remote control #6
 A B C D A+B C+D A+C B+D
- [717] / / / / / / / remote control #7
 A B C D A+B C+D A+C B+D
- [718] / / / / / / / remote control #8
 A B C D A+B C+D A+C B+D

 Please note that the User Code assigned to the remote control (sections [701] to [708]) must have the same User Options and Button Options enabled. For example, if you enable the Force Arming button option you must enable the appropriate Force Arming user option. Also, if you enable any of the Panic button options, you must enable the Panic options in the control panel.

REMOTE CONTROL ASSIGNMENT

Use the Serial Number Display (see page 25) to find out the serial number of a remote control, and then enter the serial number in the appropriate section. If you hear a rejection beep, an error has occurred or the remote control has already been assigned. To delete a remote control, enter the desired section and then enter a value of 000000 for Liberator installations, or press the [FORCE] button for Omnia installations.



Section #	Serial #	Section #	Serial #
[721]	<u> </u> / <u> </u> / <u> </u> / <u> </u> / <u> </u> / <u> </u> / <u> </u> / <u> </u> REMOTE CONTROL #1	[731]	<u> </u> / <u> </u> / <u> </u> / <u> </u> / <u> </u> / <u> </u> / <u> </u> / <u> </u> REMOTE CONTROL #1
[722]	<u> </u> / <u> </u> / <u> </u> / <u> </u> / <u> </u> / <u> </u> / <u> </u> / <u> </u> REMOTE CONTROL #2	[732]	<u> </u> / <u> </u> / <u> </u> / <u> </u> / <u> </u> / <u> </u> / <u> </u> / <u> </u> REMOTE CONTROL #2
[723]	<u> </u> / <u> </u> / <u> </u> / <u> </u> / <u> </u> / <u> </u> / <u> </u> / <u> </u> REMOTE CONTROL #3	[733]	<u> </u> / <u> </u> / <u> </u> / <u> </u> / <u> </u> / <u> </u> / <u> </u> / <u> </u> REMOTE CONTROL #3
[724]	<u> </u> / <u> </u> / <u> </u> / <u> </u> / <u> </u> / <u> </u> / <u> </u> / <u> </u> REMOTE CONTROL #4	[734]	<u> </u> / <u> </u> / <u> </u> / <u> </u> / <u> </u> / <u> </u> / <u> </u> / <u> </u> REMOTE CONTROL #4
[725]	<u> </u> / <u> </u> / <u> </u> / <u> </u> / <u> </u> / <u> </u> / <u> </u> / <u> </u> REMOTE CONTROL #5	[735]	<u> </u> / <u> </u> / <u> </u> / <u> </u> / <u> </u> / <u> </u> / <u> </u> / <u> </u> REMOTE CONTROL #5
[726]	<u> </u> / <u> </u> / <u> </u> / <u> </u> / <u> </u> / <u> </u> / <u> </u> / <u> </u> REMOTE CONTROL #6	[736]	<u> </u> / <u> </u> / <u> </u> / <u> </u> / <u> </u> / <u> </u> / <u> </u> / <u> </u> REMOTE CONTROL #6
[727]	<u> </u> / <u> </u> / <u> </u> / <u> </u> / <u> </u> / <u> </u> / <u> </u> / <u> </u> REMOTE CONTROL #7	[737]	<u> </u> / <u> </u> / <u> </u> / <u> </u> / <u> </u> / <u> </u> / <u> </u> / <u> </u> REMOTE CONTROL #7
[728]	<u> </u> / <u> </u> / <u> </u> / <u> </u> / <u> </u> / <u> </u> / <u> </u> / <u> </u> REMOTE CONTROL #8	[738]	<u> </u> / <u> </u> / <u> </u> / <u> </u> / <u> </u> / <u> </u> / <u> </u> / <u> </u> REMOTE CONTROL #8

ZONE EXPANSION BUS MODULES

Only one SPC/APR3-ZX4 or one SPC/APR3-ZX8 can be connected to each Spectra control panel. The following sections are for SPC-ZX4 version 1.0, APR3-ZX4 version 1.0, SPC-ZX8 version 1.0 and APR3-ZX8 version 1.4.



Modules with the APR- prefix are compatible with Spectra (versions 2.0 and higher) and Digiplex. Modules with the APR3- prefix are compatible with Spectra (versions 2.0 and higher), Digiplex and DigiplexNE.

Bold = Default Setting

SECTION [650]: Options

Option	OFF	ON
[1] <i>EOL (end-of-line) Resistors for hardwire modules</i>	<input type="checkbox"/> No EOL	<input type="checkbox"/> Use EOL Resistors
[2] <i>Zone Expansion Module Tamper Recognition</i>	<input type="checkbox"/> Disabled	<input type="checkbox"/> Z1 becomes tamper input
[3] <i>PGM1 on SPC/APR3-ZX8 follows Global PGM programmed in sections [124] & [125]</i>	<input type="checkbox"/> Disabled	<input type="checkbox"/> Enabled
[4]-[8] <i>Future Use</i>	<input type="checkbox"/> N/A	<input type="checkbox"/> N/A

SECTION [651]: ZONE ASSIGNMENT

Option	See "Zone Recognition Table" on page4.	OFF	ON
[1] <i>Input Z1</i>	<i>=Expansion Input 1</i>	<input type="checkbox"/> Disabled	<input type="checkbox"/> Enabled
[2] <i>Input Z2</i>	<i>=Expansion Input 2</i>	<input type="checkbox"/> Disabled	<input type="checkbox"/> Enabled
[3] <i>Input Z3</i>	<i>=Expansion Input 3</i>	<input type="checkbox"/> Disabled	<input type="checkbox"/> Enabled
[4] <i>Input Z4</i>	<i>=Expansion Input 4</i>	<input type="checkbox"/> Disabled	<input type="checkbox"/> Enabled
[5] <i>Input Z5 (SPC/APR3-ZX8 only)</i>	<i>=Expansion Input 5</i>	<input type="checkbox"/> Disabled	<input type="checkbox"/> Enabled
[6] <i>Input Z6 (SPC/APR3-ZX8 only)</i>	<i>=Expansion Input 6</i>	<input type="checkbox"/> Disabled	<input type="checkbox"/> Enabled
[7] <i>Input Z7 (SPC/APR3-ZX8 only)</i>	<i>=Expansion Input 7</i>	<input type="checkbox"/> Disabled	<input type="checkbox"/> Enabled
[8] <i>Input Z8 (SPC/APR3-ZX8 only)</i>	<i>=Expansion Input 8</i>	<input type="checkbox"/> Disabled	<input type="checkbox"/> Enabled

PGM PROGRAMMING (SPC-ZX8 and APR3-ZX8 Only)

The PGM will only activate or deactivate 100mS after the selected event occurs. The PGM Deactivation event can be used as another activation event if the PGM Timer (section [655]) is programmed with a value other than 000. The system will ignore the PGM if it has been programmed to follow the Global PGM (option [3] in section [650]). Only PGM events from the table below can be used.

Section #	Decimal Value (000-255)	Description	Default Value
[655] ___/___/___	seconds (000 = follow deactivation event)	PGM1 TIMER	5 sec.

Section #	Event Group #	Sub-Group #	Partition #
[656] PGM1 Activation Event	___/___	___/___	___/___
[657] PGM1 Deactivation Event	___/___	___/___	___/___

Event Group #	Sub-Group #	Partition #
For SPC-ZX8: 60 = Hardwire Zone Opened 61 = Hardwire Zone Closed 62 = Hardwire Tamper Opened 63 = Hardwire Tamper Closed	01 = Expansion Input 1 - Section [651] - [1] 02 = Expansion Input 2 - Section [651] - [2] 03 = Expansion Input 3 - Section [651] - [3] 04 = Expansion Input 4 - Section [651] - [4] 05 = Expansion Input 5 - Section [651] - [5] 06 = Expansion Input 6 - Section [651] - [6] 07 = Expansion Input 7 - Section [651] - [7]	Not used; enter 00
For APR3-ZX8: 60 = Hardwire Zone/Hardwire Tamper Opened 61 = Hardwire Zone/Hardwire Tamper Closed	08 = Expansion Input 8 - Section [651] - [8] 99 = Any zone expansion bus module input	

USER OPERATION

PARTITIONING

The **Spectra** system is equipped with a partitioning feature which can divide the alarm system into two distinct areas identified as Partition 1 and Partition 2. Partitioning can be used in installations where shared security systems are more practical, such as an office/warehouse building. **If the system is not partitioned, all User Codes and features will be recognized as belonging to Partition 1.**

How does a partitioned system work?

- Users can only arm or disarm their assigned partitions.
- Only zones assigned to Partition 1 will arm or disarm when Partition 1 is armed or disarmed.
- Only zones assigned to Partition 2 will arm or disarm when Partition 2 is armed or disarmed.
- Zones assigned to both partitions will arm when both partitions are armed and will disarm when at least one disarms.
- Some of the system's features can be programmed separately for each partition.

PROGRAMMING ACCESS CODES

User Access Codes are personal identification numbers that allow users to enter certain programming modes, arm or disarm the alarm system as well as activate or deactivate PGMs. **Spectra** security systems support the following:

System Master Code can arm or disarm any partition using any arming method and can create, modify or delete any *User Access Code*. Only the System Master Code can modify or delete User Access Codes assigned to both partitions.

Master Code 1 is permanently assigned to partition 1 and can be used to create, modify or delete *User Access Codes* that are assigned to partition 1.

Master Code 2 is permanently assigned to partition 2 (except when partitioning is disabled, *Master Code 2* will be assigned to partition 1) and can be used to create, modify or delete *User Access Codes* that are assigned to the same partition.

45 User Access Codes (including 1 Duress code)

How Do I Program Access Codes?

- 1) Press [ENTER]
- 2) Key in the [SYSTEM MASTER CODE] or [MASTER CODE]
- 3) Key in 3-digit [SECTION] (see User Code Table)
- 4) Key in new 4- or 6-digit [ACCESS CODE]
[ENTER] flashes. Return to step 3

How Do I Delete Access Codes?

- 1) Repeat steps 1 to 3 (see above)
- 2) Press the [FORCE] key once for each digit in the access code (4 or 6 times) until the keypad emits a Confirmation Beep.

User Code Table

Section	User Codes
[001]	User Code 001 = System Master Code
[002]	User Code 002 = Master Code 1
[003]	User Code 003 = Master Code 2
[004] to [047]	User Code 004 to User Code 047
[048]	User Code 048 or Duress Code

PROGRAMMING CHIME ZONES

This feature allows users to program which zones will be *Chime Enabled*. A *Chime Enabled* zone will cause the keypad to emit a rapid intermittent beep tone (BEEP-BEEP-BEEP-BEEP) advising the user every time it is opened. Each keypad must be Chime Programmed separately. Keypad chimes must be re-programmed if the system suffers a total power loss.

10-ZONE LED KEYPAD:

Press and hold any key from [1] to [10] for 3 seconds to activate or deactivate Chiming for zones 1 to 10. For example, press and hold the [1] key to enable chiming on zone 1. If, after pressing and holding a key, the keypad emits a confirmation beep, this means the chime feature has been enabled for that zone. If the keypad emits a Rejection Beep, this means the Chime feature has been disabled for the corresponding zone.

16-ZONE LED KEYPAD:

Press and hold the [9] key. Enter the 2-digit (01 to 16) zone number(s). When the corresponding LED is on, the zone is chimed. When the corresponding LED is off, the zone is unchimed. When the desired zones are chimed, press [ENTER].

LCD KEYPAD:

Press and hold the [9] key. Enter the 2-digit (01 to 16) zone number(s) or use the arrow keys to scroll through the zones. When the appropriate zone is displayed, press the [FNC1] key. When the desired zones are chimed, press [ENTER].

KEYPAD MUTING

Press and hold the [CLEAR] key for 3 seconds to enable or disable keypad muting. When muted, the keypad will only beep when a key is pressed or when the keypad emits a Rejection or Confirmation Beep. All other beep functions are disabled.

QUICK FUNCTION KEYS

INSTALLER TEST MODE

[ENTER] + [INSTALLER CODE] + [TBL] or [TRBL]

The Installer Test Mode allows you to perform walk tests where the bell/siren will squawk once to indicate an open zone and twice to indicate a closed zone. To enter this mode, press [ENTER] + [INSTALLER CODE] + [TBL] or [TRBL]. The keypad will emit a Confirmation Beep. To disable this mode, press the [TBL] or [TRBL] key again. The keypad will emit a Rejection Beep.

TEST REPORT

[ENTER] + [INSTALLER/MASTER CODE] + [MEM]

Sends the "Test Report" report code programmed in section [211] to the central station.

CALL WINLOAD SOFTWARE

[ENTER] + [INSTALLER/MASTER CODE] + [BYP]

This feature is used to establish communication between the control panel and a computer using the WinLoad Software. After entering this mode, the control panel will dial the telephone number programmed in section [150].

CANCEL COMMUNICATION

[ENTER] + [INSTALLER/MASTER CODE] + [STAY]

Cancels all communication until the next reportable event. If the Master Code was used, only communication with WinLoad would be cancelled.

ANSWER WINLOAD SOFTWARE

[ENTER] + [INSTALLER/MASTER CODE] + [FORCE]

Forces the control panel to pick-up an incoming telephone call.

APPENDIX A - ADEMCO CID REPORT CODE LIST (PROG.)

If using the Ademco Contact ID Programmable code format, enter the 2-digit hexadecimal value from the table below (**Prog. Value**) into sections [160] to [213] to program the desired report codes. **To enter a 0 value press the [FORCE] key.**

CID#	Reporting Code	Prog. Value	CID#	Reporting Code	Prog. Value	CID#	Reporting Code	Prog. Value
MEDICAL ALARMS - 100			204	Low Water Level	2F	403	Automatic O/C	5D
100	Medical Alarm	01	205	Pump Activated	30	404	Late to O/C	5E
101	Pendant Transmitter	02	206	Pump Failure	31	405	Deferred	5F
102	Fail to Report In	03	SYSTEM TROUBLES - 300 & 310			406	Cancel	60
FIRE ALARMS - 110			300	System Trouble	32	407	Remote Arm/Disarm	61
110	Fire Alarm	04	301	AC Loss	33	408	Quick Arm	62
111	Smoke	05	302	Low System Battery	34	409	Keyswitch O/C	63
112	Combustion	06	303	RAM Checksum Bad	35	REMOTE ACCESS - 410		
113	Water Flow	07	304	ROM Checksum Bad	36	411	Callback Request Made	64
114	Heat	08	305	System Reset	37	412	Success - Download Access	65
115	Pull Station	09	306	Panel Program Changed	38	413	Unsuccessful Access	66
116	Duct	0A	307	Self-Test Failure	39	414	System Shutdown	67
117	Flame	0B	308	System Shutdown	3A	415	Dialer Shutdown	68
118	Near Alarm	0C	309	Battery Test Failure	3B	ACCESS CONTROL - 420		
PANIC ALARMS - 120			310	Ground Fault	3C	421	Access Denied	69
120	Panic Alarm	0D	SOUNDER/RELAY TROUBLES - 320			422	Access Report By User	6A
121	Duress	0E	320	Sounder Relay	3D	SOUNDER RELAY DISABLES - 520		
122	Silent	0F	321	Bell 1	3E	520	Sounder/Relay Disabled	6B
123	Audible	10	322	Bell 2	3F	521	Bell 1 Disable	6C
BURGLAR ALARMS - 130			323	Alarm Relay	40	522	Bell 2 Disable	6D
130	Burglary	11	324	Trouble Relay	41	523	Alarm Relay Disable	6E
131	Perimeter	12	325	Reversing	42	524	Trouble Relay Disable	6F
132	Interior	13	SYSTEM PERIPHERAL TROUBLES - 330 & 340			525	Reversing Relay Disable	70
133	24-Hour	14	330	System Peripheral	43	COMMUNICATION DISABLES - 550 & 560		
134	Entry/Exit	15	331	Polling Loop Open	44	551	Dialer Disabled	71
135	Day/Night	16	332	Polling Loop Short	45	552	Radio xmitter Disabled	72
136	Outdoor	17	333	Exp. Module Failure	46	BYPASSES - 570		
137	Tamper	18	334	Repeater Failure	47	570	Zone Bypass	73
138	Near Alarm	19	335	Local Printer Paper Out	48	571	Fire Bypass	74
GENERAL ALARMS - 140			336	Local Printer Failure	49	572	24-Hour Zone Bypass	75
140	General Alarm	1A	COMMUNICATION TROUBLES - 350 & 360			573	Burg. Bypass	76
141	Polling Loop Open	1B	350	Communication	4A	574	Group Bypass	77
142	Polling Loop Short	1C	351	Telco Fault 1	4B	TEST/MISC. - 600		
143	Expansion Module Failure	1D	352	Telco Fault 2	4C	601	Manual Trigger Test	78
144	Sensor Tamper	1E	353	Long Range Radio	4D	602	Periodic Test Report	79
145	Expansion Module Tamper	1F	354	Fail to Communicate	4E	603	Periodic RF Xmission	7A
24-HOUR NON-BURGLARY - 150 & 160			355	Loss of Radio Supervision	4F	604	Fire Test	7B
150	24-Hour Non-Burglary	20	356	Loss of Central Polling	50	605	Status Report to Follow	7C
151	Gas Detected	21	PROTECTION LOOP TROUBLES - 370			606	Listen-in to Follow	7D
152	Refrigeration	22	370	Protection Loop	51	607	Walk Test Mode	7E
153	Loss of Heat	23	371	Protection Loop Open	52	621	Event Log Reset	7F
154	Water Leakage	24	372	Protection Loop short	53	622	Event Log 50% Full	80
155	Foil Break	25	373	Fire Trouble	54	623	Event Log 90% Full	81
156	Day Trouble	26	SENSOR TROUBLES - 380			624	Event Log Overflow	82
157	Low Bottled Gas Level	27	380	Sensor Trouble	55	625	Time/Date Reset	83
158	High Temp	28	381	Loss of Super. -RF	56	626	Time/Date Inaccurate	84
159	Low Temp	29	382	Loss of Super. - RPM	57	627	Program Mode Entry	85
161	Loss of Air Flow	2A	383	Sensor Tamper	58	628	Program Mode Exit	86
FIRE SUPERVISORY - 200 & 210			384	RF xmtr. Low Battery	59	631	Exception Schedule Change	87
200	Fire Supervisory	2B	OPEN/CLOSE - 400					
201	Low Water Pressure	2C	400	Open/Close	5A			
202	Low CO2	2D	401	O/C by User	5B			
203	Gate Valve Sensor	2E	402	Group O/C	5C			

APPENDIX B - ADEMCO CID REPORT CODE LIST (ALL CODES)

System Event	Default Contact ID Report Code when option [3] is on in section [136]
Arming with Master Code (##)	3 4A1 - Close by user
Arming with User Code (##)	3 4A1 - Close by user
Arming with Keypad (##)	3 4A9 - Keypad Close
Auto Arming	3 4A3 - Automatic Close
Arm with PC software	3 4A7 - Remote arm/disarm
Late To Close	3 4A4 - Late to Close
No Movement	3 4A4 - Late to Close
Partial arming	1 574 - Group bypass
Quick arming	3 408 - Quick arm
Disarm with Master Code (##)	1 4A1 - Open by user
Disarm with User Code (##)	1 4A1 - Open by user
Disarm with Keypad (##)	1 4A9 - Keypad Open
Disarm after alarm with Master Code (##)	1 4A1 - Open by user
Disarm after alarm with User Code (##)	1 4A1 - Open by user
Disarm after alarm with Keypad (##)	1 4A9 - Keypad Open
Auto Arming Cancellation	1 4A5 - Deferred Open/Close
Disarm with PC software	1 4A7 - Remote arm/disarm
Disarm after an alarm with PC software	1 4A7 - Remote arm/disarm
Zone Bypassed (##)	1 57A - Zone bypass
Zone alarm (##)	1 13A - Burglary Alarm
Fire alarm (##)	1 11A - Fire alarm
Zone alarm restore (##)	3 13A - Burglary Alarm Restore
Fire alarm restore (##)	3 11A - Fire alarm Restore
Panic 1 - Emergency	1 12A - Panic alarm
Panic 2 - Medical	1 1AA - Medical alarm
Panic 3 - Fire	1 115 - Pull Station
Recent closing	3 4AA - Open/Close
Global zone shutdown	1 574 - Group bypass
Duress alarm	1 121 - Duress
Zone shutdown (##)	1 57A - Zone bypass
Zone tampered (##)	1 144 - Sensor tamper
Zone tamper restore (##)	3 144 - Sensor tamper restore
AC Failure	1 3A1 - AC loss
Battery Failure	1 3A9 - Battery test failure
Auxiliary supply trouble	1 3AA - System trouble
Bell output current limit	1 321 - Bell 1

System Event	Default Contact ID Report Code when option [3] is on in section [136]
Bell absent	1 321 - Bell 1
Clock lost	1 626 - Time/Date inaccurate
Fire loop trouble	1 373 - Fire trouble
Wireless Transmitter Low Battery	1 384 - RF xmtr. low battery
Wireless Transmitter Supervision Loss	1 381 - Loss of super. - RF
Module fault	1 333 - Expansion module failure
Printer fault	1 336 - Local printer failure
Fail to communicate with central station	1 354 - Fail to communicate
TLM trouble restore	3 351 - Telco 1 fault restore
AC Failure restore	3 3A1 - AC loss restore
Battery Failure restore	3 3A9 - Battery test restore
Auxiliary supply trouble restore	3 3AA - System trouble restore
Bell output current limit restore	3 321 - Bell 1 restore
Bell absent restore	3 321 - Bell 1 restore
Clock programmed	3 626 - Time/Date Reset
Fire loop trouble restore	3 373 - Fire trouble restore
Wireless Transmitter Low Battery	3 384 - RF xmtr. low battery
Wireless Transmitter Supervision Loss	3 381 - Loss of super. - RF
Module fault restore	3 333 - Expansion module failure restore
Printer fault restore	3 336 - Local printer failure restore
Fail to communicate with central station	3 354 - Fail to communicate restore
Cold Start	1 3A8 - System shutdown
Test Report engaged	1 6A2 - Periodic test report
PC software communication finished	1 412 - Successful - download access
Installer on site	1 627 - Program mode Entry
Installer programming finished	1 628 - Program mode Exit

BUS MODULE CONNECTIONS

PRINTER BUS MODULE (APR3-PRT1)

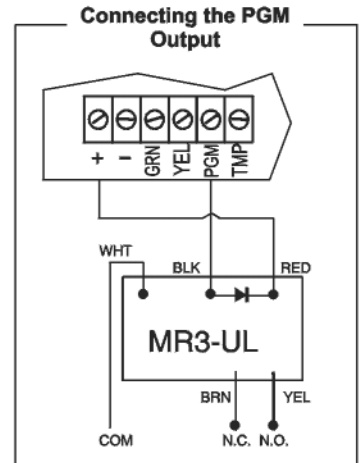
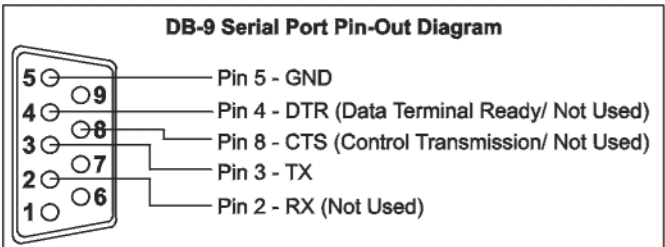
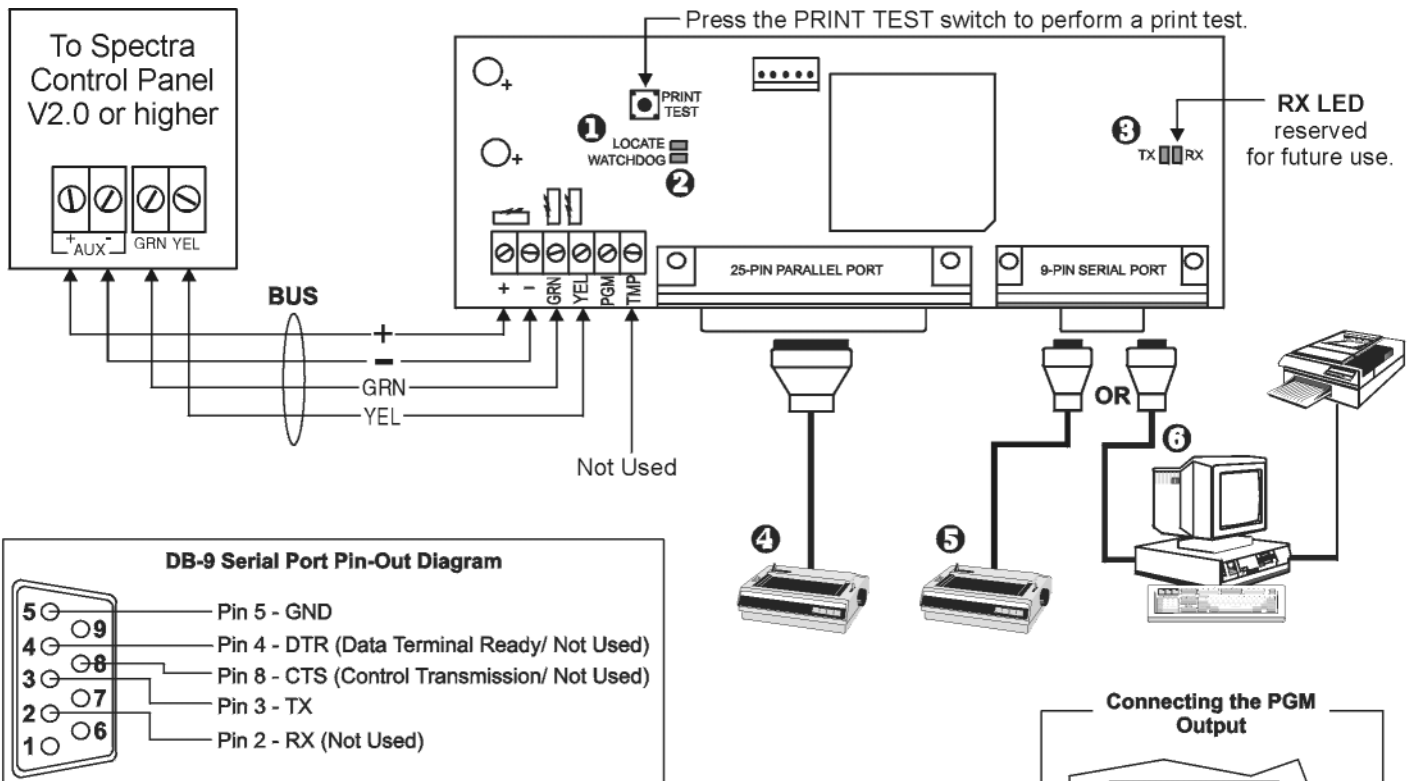

- ❶ **Green "Locate" LED:** Remains illuminated during power up
- ❷ **Red "Watchdog" LED:** Flashes to indicate proper operation. If there is a communication failure, the red LED will flash ON for one second and OFF for one second.
- ❸ **Red "TX" LED:** Flashes when the Printer Module is transmitting data through the serial port only.
- ❹ **25-Pin Parallel Port:** Connect the Printer Module's 25-pin parallel port to any dot matrix printer. **Note: The dot matrix printer must support a minimum of 80 columns.**
- ❺ **9-Pin Serial Port:** Connect the Printer Module's 9-Pin serial port to a dot matrix printer. **Note: The dot matrix printer must support a minimum of 80 columns.**
- ❻ **9-Pin Serial Port:** Connect the Printer Module's 9-pin serial port to a computer's COM port to view the control panel's events on the computer's monitor. The events displayed on the monitor can then be printed through the printer connected to the computer.



Remove AC power and battery before adding a bus module to the system. Do not connect any expansion modules more than 250 feet (76m) from the control panel. Only one Printer Module can be connected per Spectra control panel.

4-OUTPUT BUS MODULE (APR3-PGM4)

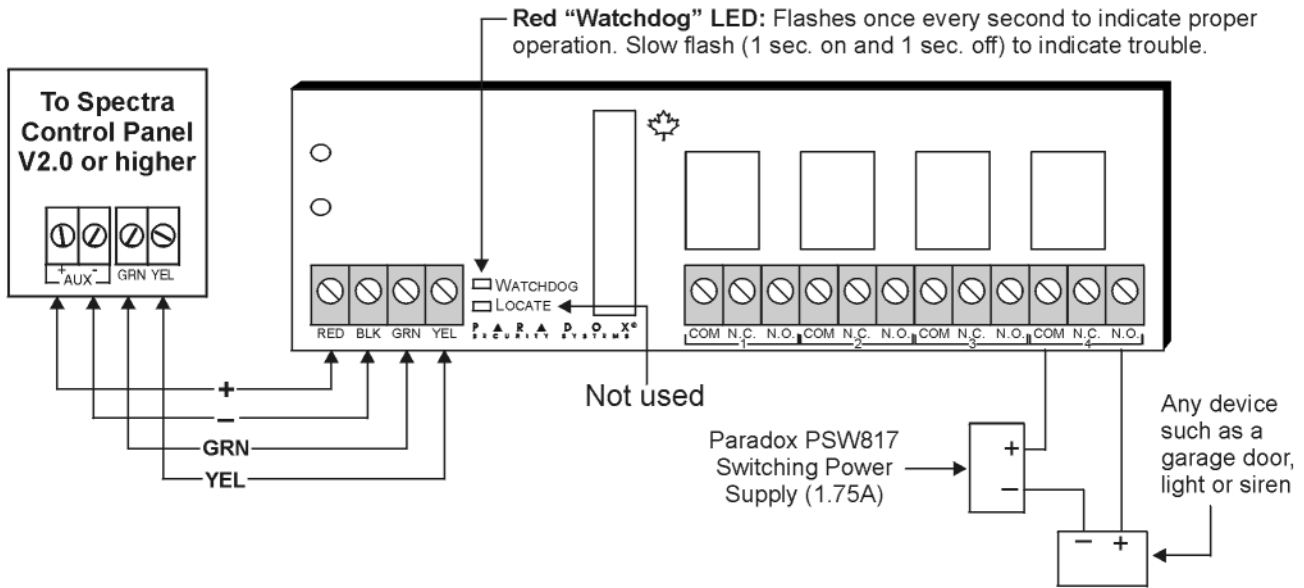

Remove AC power and battery before adding a bus module to the system. Do not connect any expansion modules more than 250 feet (76m) from the control panel. Only one 4-Output Bus Module can be connected per Spectra control panel.

4-ZONE EXPANSION BUS MODULE (SPC-ZX4 AND APR3-ZX4)

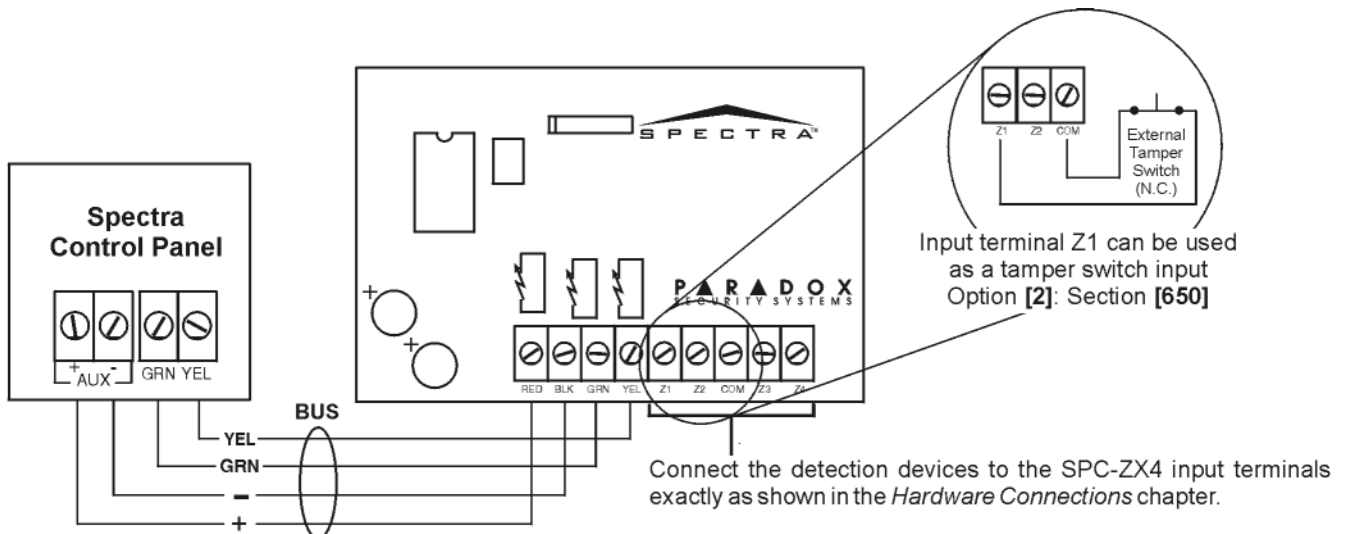

Remove AC power and battery before adding a bus module to the system. Do not connect any expansion modules more than 250 feet (76m) from the control panel. Only one 4-zone Expansion Bus Module (SPC-ZX4) can be connected per Spectra control panel.



VOICE-ASSISTED ARM/DISARM BUS MODULE (APR3-ADM2)

! Remove AC and battery power from the control panel before adding the APR3-ADM2 module to the system. Do not connect any expansion modules more than 250 feet (76m) from the control panel.

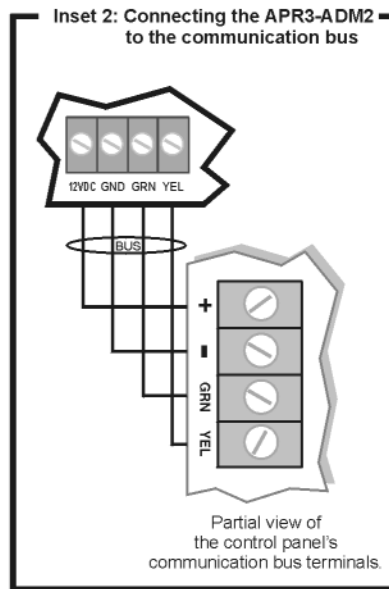
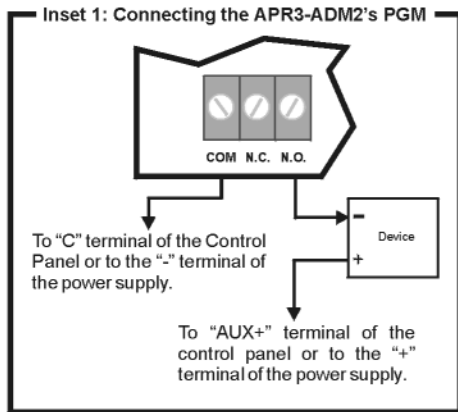
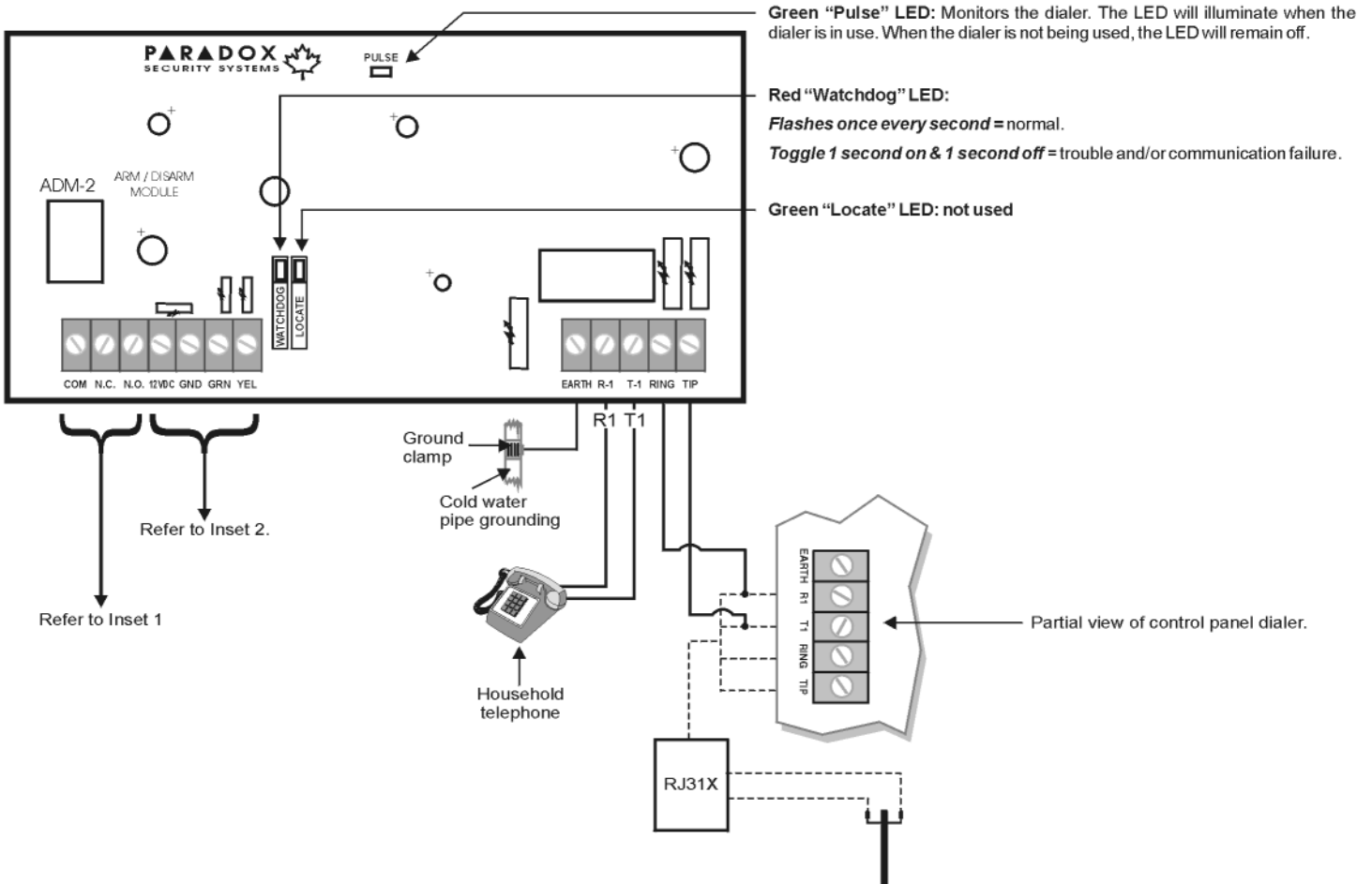

8-ZONE EXPANSION BUS MODULES (SPC-ZX8 AND APR3-ZX8)

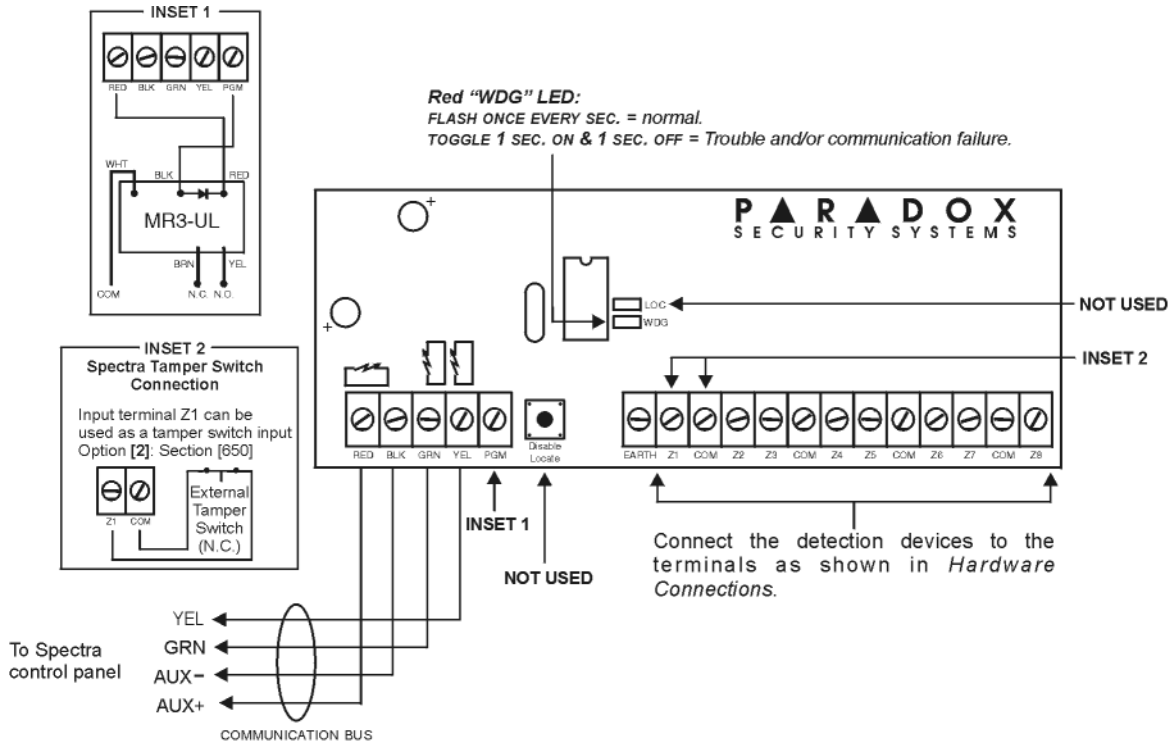

! Remove AC power and battery before adding a module to the system. Do not connect any expansion modules more than 250 feet (76m) from the control panel. Only one SPC-ZX8 or APR3-ZX8 can be connected per Spectra control panel. The SPC-ZX8 or APR3-ZX8 does not support the ATZ feature when connected to the Spectra control panel.

900MHZ WIRELESS BUS MODULE (SPC-319)

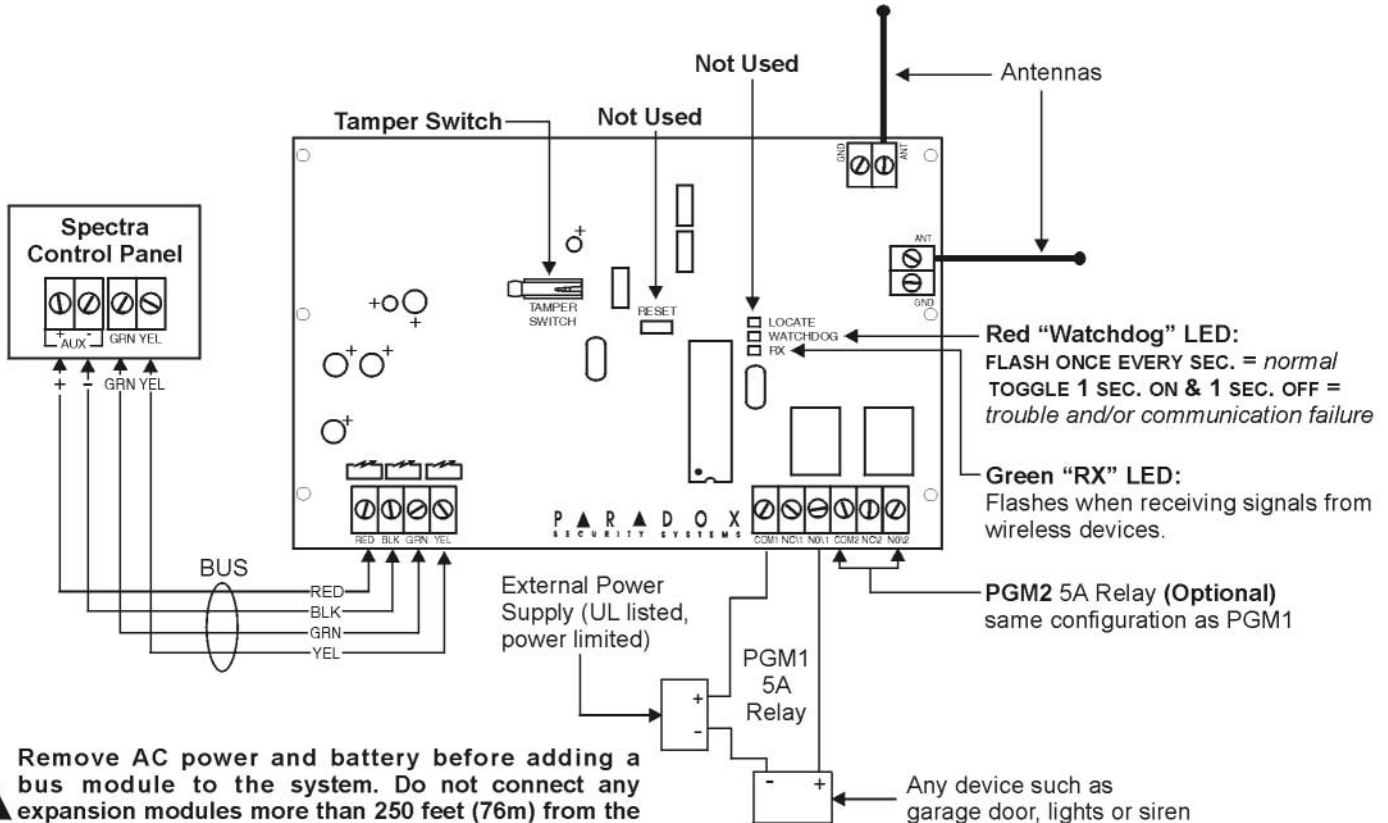

! Remove AC power and battery before adding a bus module to the system. Do not connect any expansion modules more than 250 feet (76m) from the control panel. Only one Liberator Wireless Bus Module (SPC-319) can be connected per Spectra control panel.

OMNIA WIRELESS RECEIVER (OMN-RCV3)

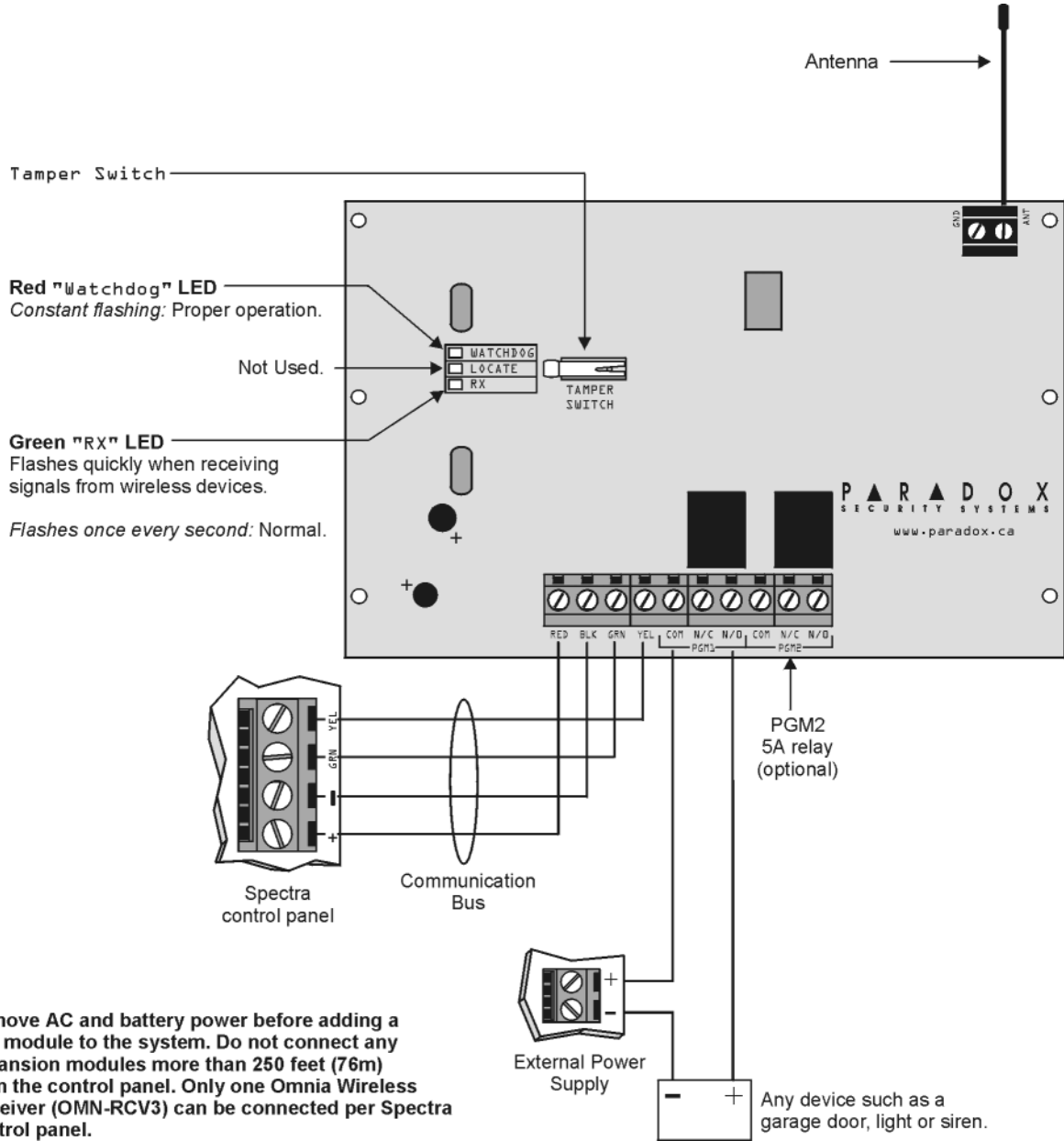

! Remove AC and battery power before adding a bus module to the system. Do not connect any expansion modules more than 250 feet (76m) from the control panel. Only one Omnia Wireless Receiver (OMN-RCV3) can be connected per Spectra control panel.

HARDWARE CONNECTIONS

SINGLE ZONE INPUTS

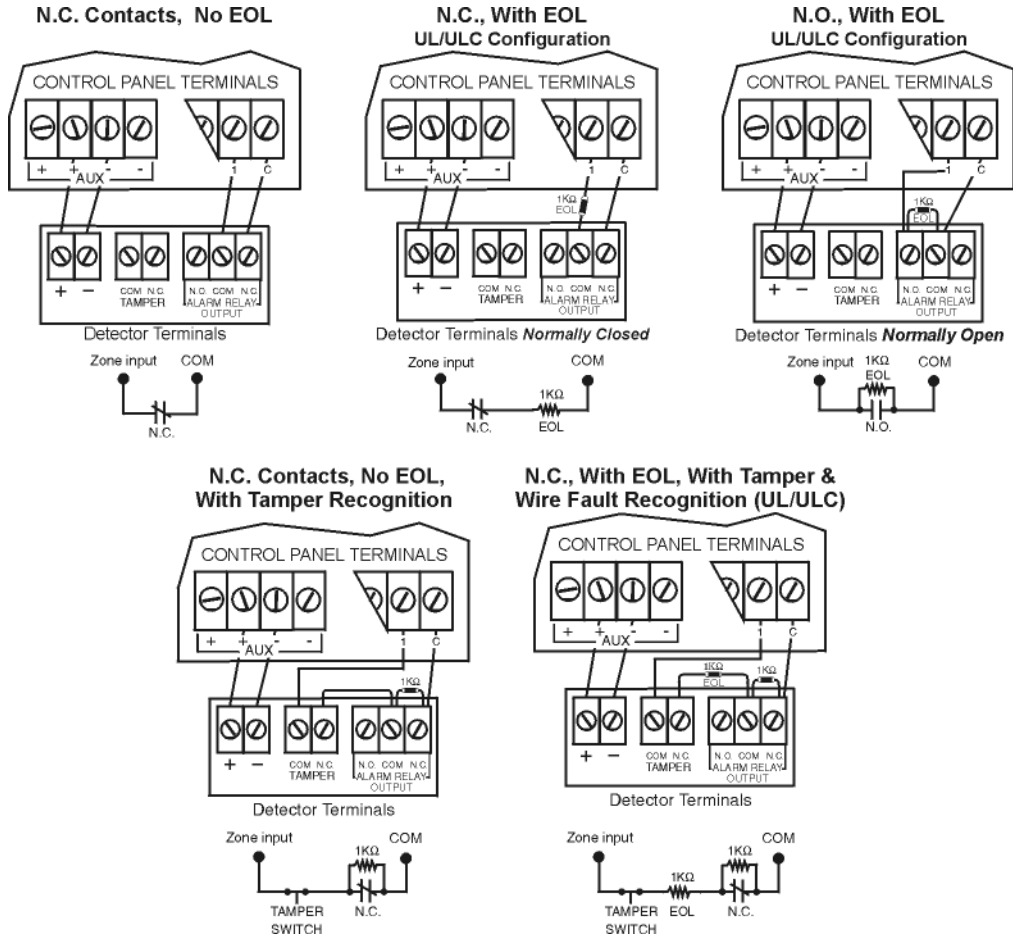

DOUBLE ZONE INPUTS (with ATZ option only)

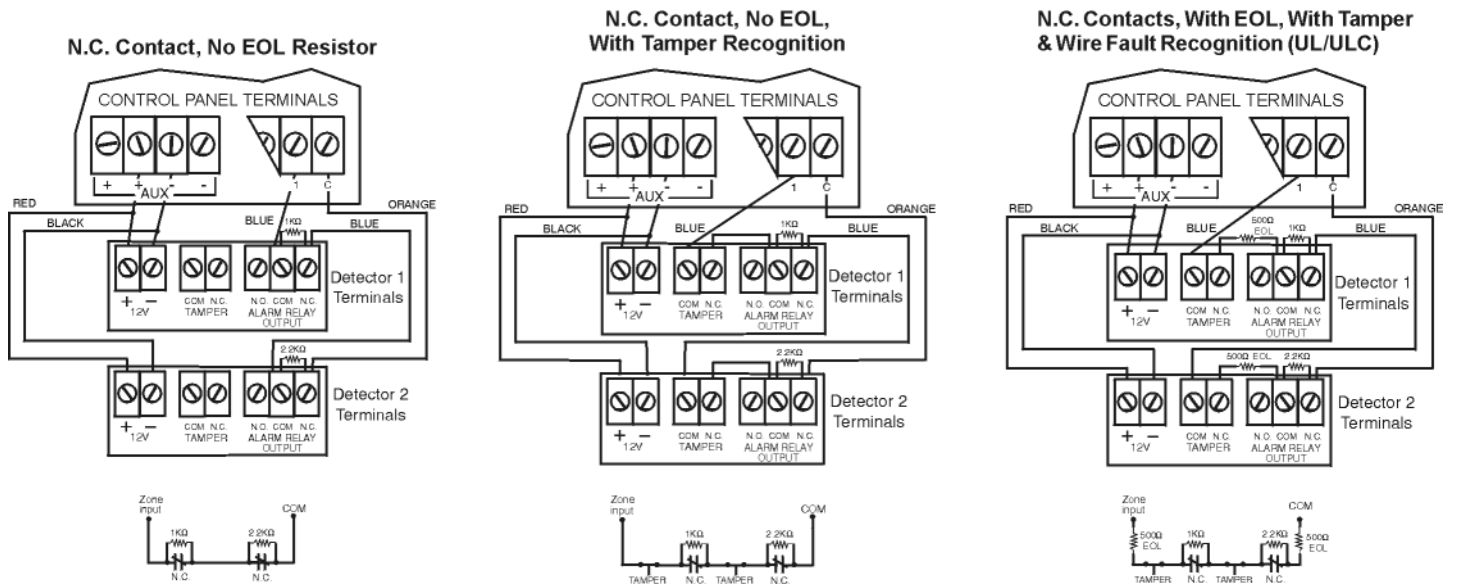

CONNECTING FIRE CIRCUITS, KEYSWITCHES AND PGMS

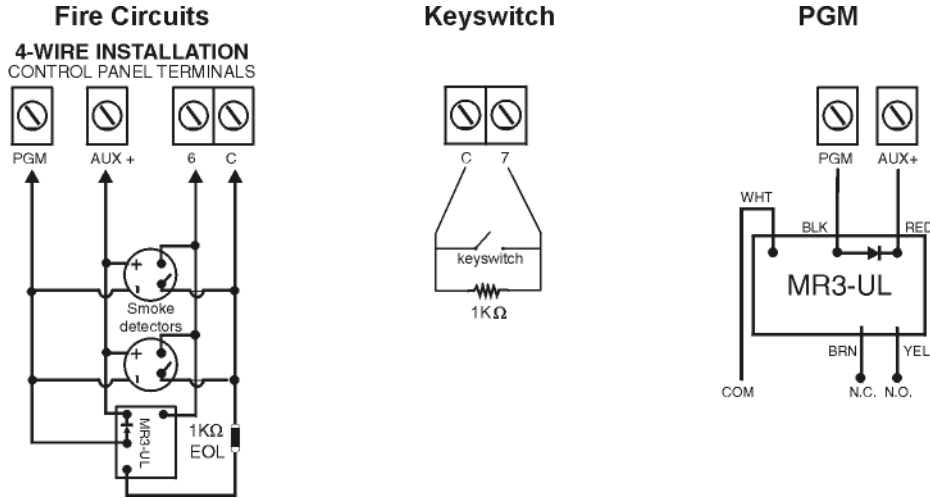

ALARM RELAY AND PGM2 CONNECTIONS FOR 1738 AND 1738EX

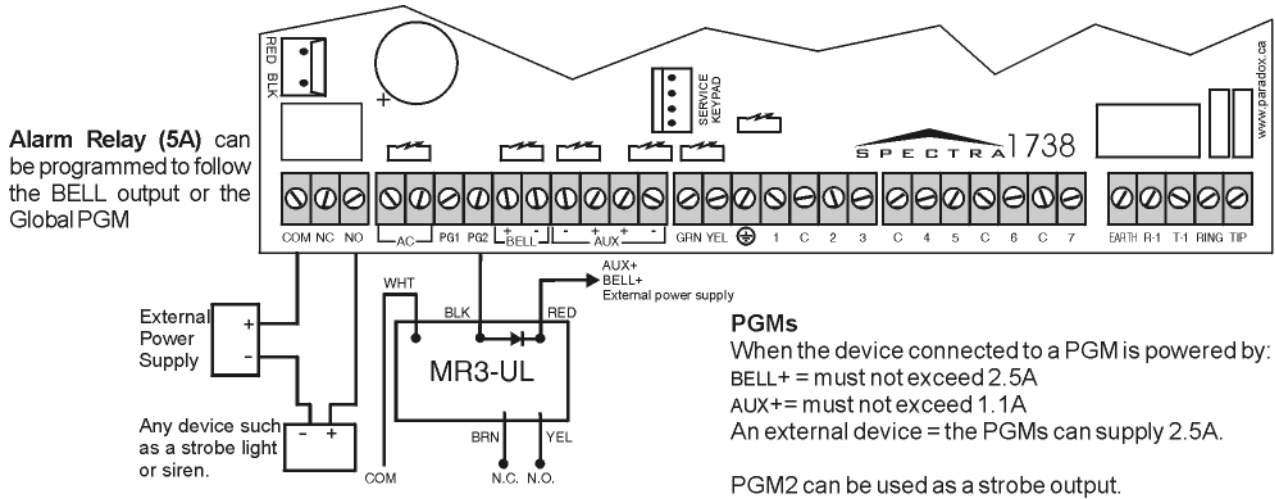

CONNECTING MORE THAN TWO KEYPADS

If there are more than 2 keypads connected to the control panel and at least one keypad zone is being used, connect as shown and program as described in the *Spectra Control Panels Reference & Installation* manual.

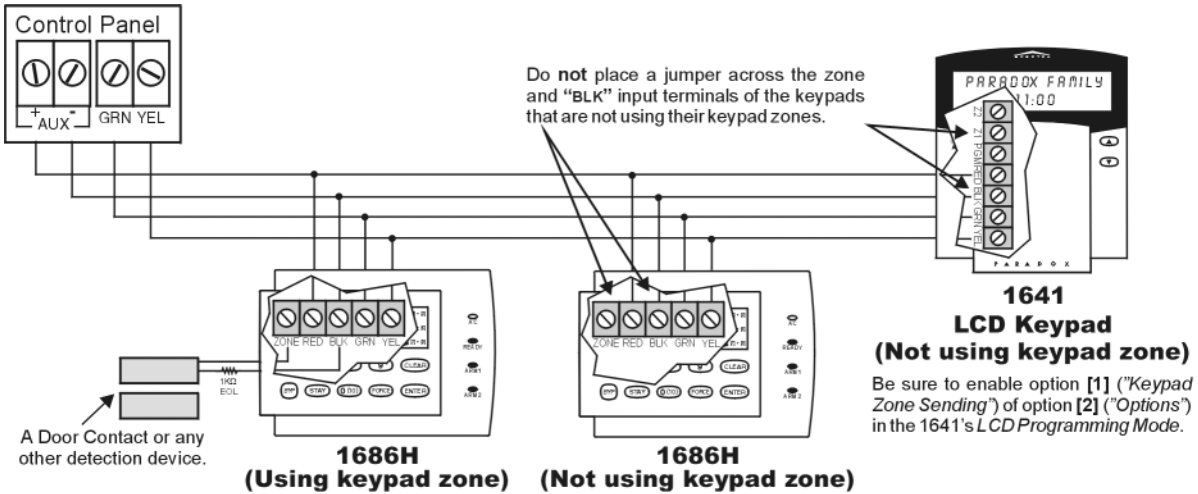

SPECTRA 1728 AND 1728EX PCB LAYOUT

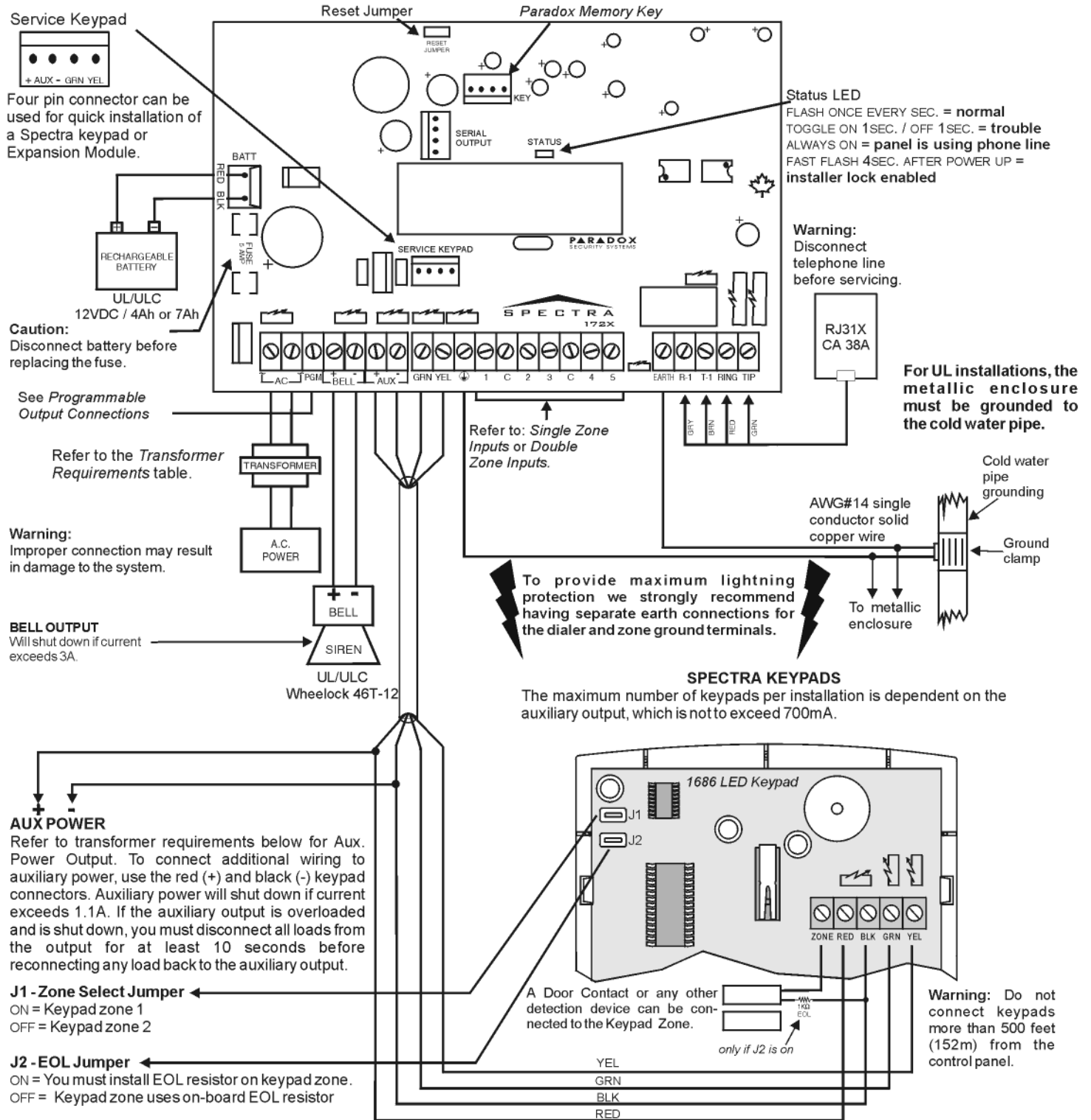

All outputs are Class 2 or power-limited, except for the battery terminal. The Class 2 and power-limited fire alarm circuits shall be installed using CL3, CL3R, CL3P, or substitute cable permitted by the National Electrical Code, ANSI/NFPA 70.

Transformer Requirements Table

Transformer:	Min. 16VAC 20VA UL: Amseco XP-1620	Recommend: 16VAC 40VA UL: Basler Electric BE156240CAA007
Spectra DC Power Supply rated at:	1.2A	1.5A
Auxiliary Supply can provide a maximum of:	typ: 600mA, max: 700mA	typ: 600mA, max: 700mA
Acceptable Battery Charge Currents (section [127] option [5])	350mA	350mA/700mA

SPECTRA 1738 AND 1738EX PCB LAYOUT

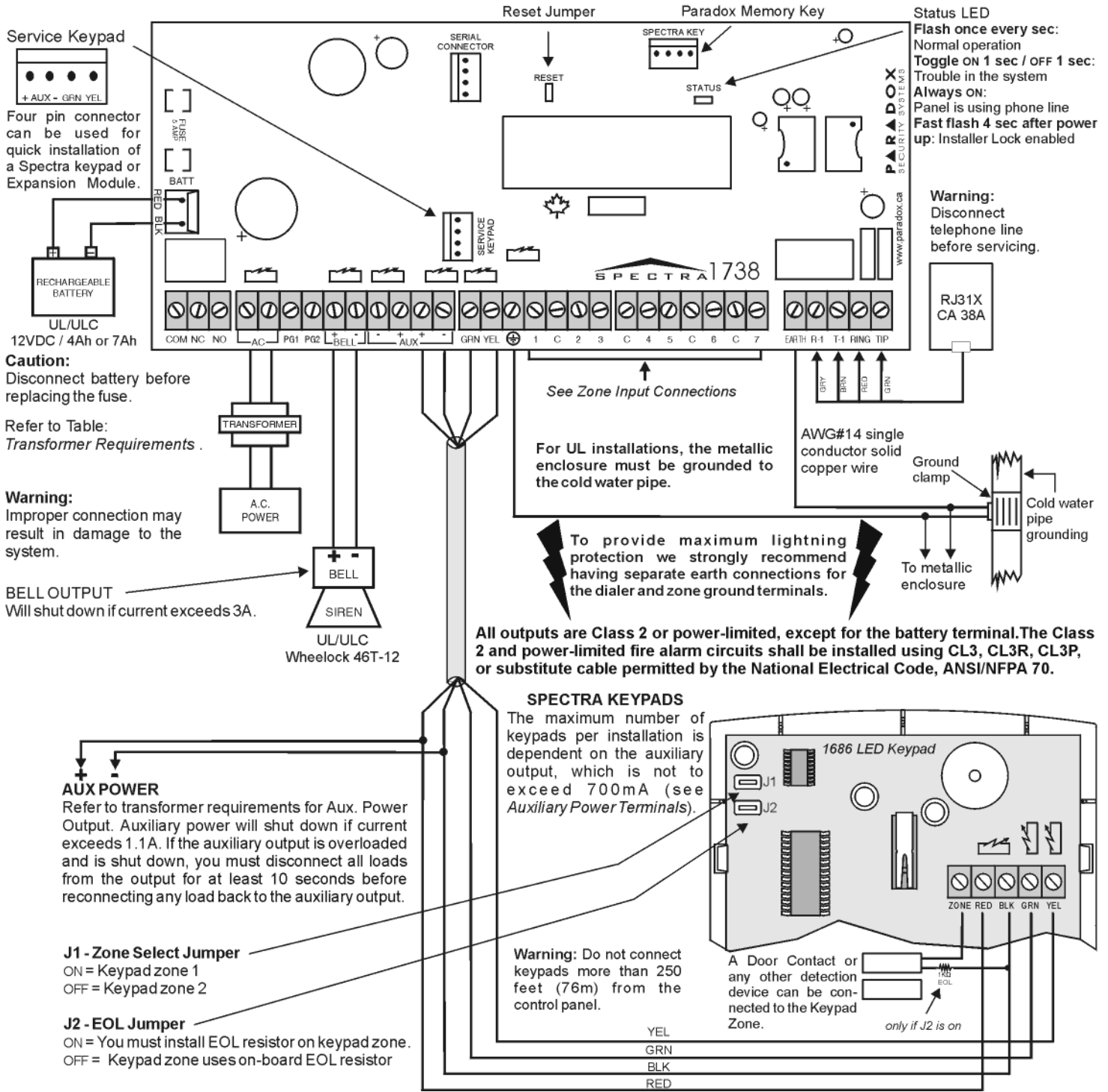

Transformer Requirements Table

Transformer:	Min. 16.5VAC 37VA UL: ATC-Frost FTC3716	Rec: 16.5VAC 40VA UL: ATC-Frost FPS4016
Spectra DC Power Supply rated at:	1.2A	1.5A
Auxiliary Supply can provide a maximum of:	typ: 600mA, max: 700mA	typ: 600mA, max: 700mA
Acceptable Battery Charge Currents (<i>section [127] option [5]</i>)	350mA	350mA/700mA

P ▲ R ▲ D O X[®]
S E C U R I T Y S Y S T E M S
780 Boul. Industriel, St-Eustache, Montréal, Québec, Canada J7R 5V3
Fax: (450) 491-2313 **www.paradox.ca**

PRINTED IN CANADA 09/2001

17X8EP-03